

Table of Contents

| | | | | | |
|-----|--|----|------|--|----|
| 1 | Family Configurations | 3 | 2.10 | Mini-FlexBus External Interface Specifications | 32 |
| 1.1 | Block Diagram | 4 | 2.11 | Fast Ethernet Timing Specifications | 33 |
| 1.2 | Features | 4 | 2.12 | General Purpose I/O Timing | 35 |
| 2 | Electrical Characteristics | 24 | 2.13 | Reset Timing | 36 |
| 2.1 | Maximum Ratings | 24 | 2.14 | I2C Input/Output Timing Specifications | 37 |
| 2.2 | Current Consumption | 25 | 2.15 | Analog-to-Digital Converter (ADC) Parameters | 38 |
| 2.3 | Thermal Characteristics | 26 | 2.16 | Equivalent Circuit for ADC Inputs | 39 |
| 2.4 | Flash Memory Characteristics | 28 | 2.17 | DMA Timers Timing Specifications | 40 |
| 2.5 | EzPort Electrical Specifications | 29 | 2.18 | QSPI Electrical Specifications | 40 |
| 2.6 | ESD Protection | 29 | 2.19 | JTAG and Boundary Scan Timing | 40 |
| 2.7 | DC Electrical Specifications | 30 | 2.20 | Debug AC Timing Specifications | 43 |
| 2.8 | Clock Source Electrical Specifications | 31 | 3 | Package Information | 44 |
| 2.9 | USB Operation | 32 | 4 | Revision History | 45 |

1 Family Configurations

Table 1. MCF52259 Family Configurations

| Module | 52252 | 52254 | 52255 | 52256 | 52258 | 52259 |
|---|---------------------------------|--------|---------------------------|---------------------------------|--------|---------------------------|
| Version 2 ColdFire Core with eMAC (Enhanced multiply-accumulate unit) and CAU (Cryptographic acceleration unit) | • | • | • | • | • | • |
| System Clock | up to 66 or 80 MHz ¹ | | up to 80 MHz ¹ | up to 66 or 80 MHz ¹ | | up to 80 MHz ¹ |
| Performance (Dhrystone 2.1 MIPS) | up to 63 or 76 | | | | | |
| Flash | 256 KB | 512 KB | 512 KB | 256 KB | 512 KB | 512 KB |
| Static RAM (SRAM) | 32 KB | 64 KB | 64 KB | 32 / 64 KB | 64 KB | 64 KB |
| Two Interrupt Controllers (INTC) | • | • | • | • | • | • |
| Fast Analog-to-Digital Converter (ADC) | • | • | • | • | • | • |
| USB On-The-Go (USB OTG) | • | • | • | • | • | • |
| Mini-FlexBus external bus interface | — | — | — | • | • | • |
| Fast Ethernet Controller (FEC) | • | • | • | • | • | • |
| Random Number Generator and Cryptographic Acceleration Unit (CAU) | — | — | • | — | — | • |
| FlexCAN 2.0B Module | Varies | Varies | • | Varies | Varies | • |
| Four-channel Direct-Memory Access (DMA) | • | • | • | • | • | • |
| Software Watchdog Timer (WDT) | • | • | • | • | • | • |
| Secondary Watchdog Timer | • | • | • | • | • | • |
| Two-channel Periodic Interrupt Timer (PIT) | 2 | 2 | 2 | 2 | 2 | 2 |
| Four-Channel General Purpose Timer (GPT) | • | • | • | • | • | • |
| 32-bit DMA Timers | 4 | 4 | 4 | 4 | 4 | 4 |
| QSPI | • | • | • | • | • | • |
| UART(s) | 3 | 3 | 3 | 3 | 3 | 3 |
| I2C | 2 | 2 | 2 | 2 | 2 | 2 |
| Eight/Four-channel 8/16-bit PWM Timer | • | • | • | • | • | • |
| General Purpose I/O Module (GPIO) | • | • | • | • | • | • |
| Chip Configuration and Reset Controller Module | • | • | • | • | • | • |
| Background Debug Mode (BDM) | • | • | • | • | • | • |
| JTAG - IEEE 1149.1 Test Access Port | • | • | • | • | • | • |
| Package | 100 LQFP | | | 144 LQFP or 144 MAPBGA | | |

¹ 66 MHz = 63 MIPS; 80 MHz = 76 MIPS

1.1 Block Diagram

Figure 1 shows a top-level block diagram of the device. Package options for this family are described later in this document.

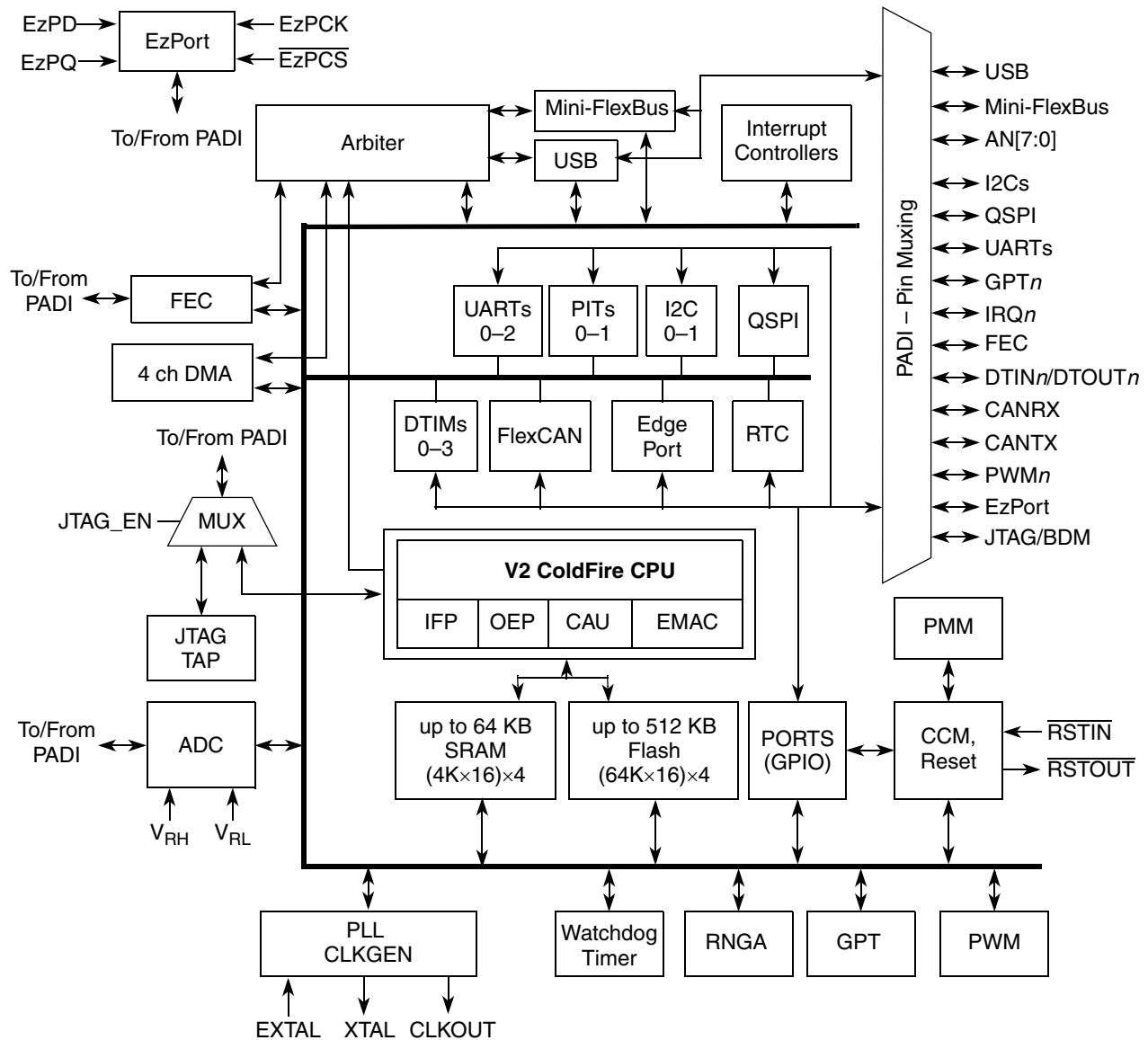

Figure 1. MCF52259 Block Diagram

1.2 Features

1.2.1 Feature Overview

The MCF52259 family includes the following features:

- Version 2 ColdFire variable-length RISC processor core
 - Static operation
 - 32-bit address and data paths on-chip

Family Configurations

- Up to 80 MHz processor core frequency
- 40 MHz or 33 MHz peripheral bus frequency
- Sixteen general-purpose, 32-bit data and address registers
- Implements ColdFire ISA_A with extensions to support the user stack pointer register and four new instructions for improved bit processing (ISA_A+)
- Enhanced Multiply-Accumulate (EMAC) unit with four 32-bit accumulators to support $16 \times 16 \rightarrow 32$ or $32 \times 32 \rightarrow 48$ operations
- Cryptographic Acceleration Unit (CAU)
 - Tightly-coupled coprocessor to accelerate software-based encryption and message digest functions
 - Support for DES, 3DES, AES, MD5, and SHA-1 algorithms
- System debug support
 - Real-time trace for determining dynamic execution path
 - Background debug mode (BDM) for in-circuit debugging (DEBUG_B+)
 - Real-time debug support, with six hardware breakpoints (4 PC, 1 address and 1 data) configurable into a 1- or 2-level trigger
- On-chip memories
 - Up to 64 KB dual-ported SRAM on CPU internal bus, supporting core, DMA, and USB access with standby power supply support for the first 16 KB
 - Up to 512 KB of interleaved flash memory supporting 2-1-1-1 accesses
- Power management
 - Fully static operation with processor sleep and whole chip stop modes
 - Rapid response to interrupts from the low-power sleep mode (wake-up feature)
 - Clock enable/disable for each peripheral when not used (except backup watchdog timer)
 - Software controlled disable of external clock output for low-power consumption
- FlexCAN 2.0B module
 - Based on and includes all existing features of the Freescale TouCAN module
 - Full implementation of the CAN protocol specification version 2.0B
 - Standard data and remote frames (up to 109 bits long)
 - Extended data and remote frames (up to 127 bits long)
 - Zero to eight bytes data length
 - Programmable bit rate up to 1 Mbit/s
 - Flexible message buffers (MBs), totalling up to 16 message buffers of 0–8 byte data length each, configurable as Rx or Tx, all supporting standard and extended messages
 - Unused MB space can be used as general purpose RAM space
 - Listen-only mode capability
 - Content-related addressing
 - No read/write semaphores
 - Three programmable mask registers: global for MBs 0–13, special for MB14, and special for MB15
 - Programmable transmit-first scheme: lowest ID or lowest buffer number
 - Time stamp based on 16-bit free-running timer
 - Global network time, synchronized by a specific message
 - Maskable interrupts
- Universal Serial Bus On-The-Go (USB OTG) dual-mode host and device controller
 - Full-speed / low-speed host controller
 - USB 1.1 and 2.0 compliant full-speed / low speed device controller
 - 16 bidirectional end points

- DMA or FIFO data stream interfaces
- Low power consumption
- OTG protocol logic
- Fast Ethernet controller (FEC)
 - 10/100 BaseT/TX capability, half duplex or full duplex
 - On-chip transmit and receive FIFOs
 - Built-in dedicated DMA controller
 - Memory-based flexible descriptor rings
- Mini-FlexBus
 - External bus interface available on 144 pin packages
 - Supports glueless interface with 8-bit ROM/flash/SRAM/simple slave peripherals. Can address up to 2 MB of addresses
 - 2 chip selects ($\overline{\text{FB_CS}}[1:0]$)
 - Non-multiplexed mode: 8-bit dedicated data bus, 20-bit address bus
 - Multiplexed mode: 16-bit data and 20-bit address bus
 - FB_CLK output to support synchronous memories
 - Programmable base address, size, and wait states to support slow peripherals
 - Operates at up to 40 MHz (bus clock) in 1:2 mode or up to 80 MHz (core clock) in 1:1 mode
- Three universal asynchronous/synchronous receiver transmitters (UARTs)
 - 16-bit divider for clock generation
 - Interrupt control logic with maskable interrupts
 - DMA support
 - Data formats can be 5, 6, 7, or 8 bits with even, odd, or no parity
 - Up to two stop bits in 1/16 increments
 - Error-detection capabilities
 - Modem support includes request-to-send (RTS) and clear-to-send (CTS) lines for two UARTs
 - Transmit and receive FIFO buffers
- Two I2C modules
 - Interchip bus interface for EEPROMs, LCD controllers, A/D converters, and keypads
 - Fully compatible with industry-standard I2C bus
 - Master and slave modes support multiple masters
 - Automatic interrupt generation with programmable level
- Queued serial peripheral interface (QSPI)
 - Full-duplex, three-wire synchronous transfers
 - Up to three chip selects available
 - Master mode operation only
 - Programmable bit rates up to half the CPU clock frequency
 - Up to 16 pre-programmed transfers
- Fast analog-to-digital converter (ADC)
 - Eight analog input channels
 - 12-bit resolution
 - Minimum 1.125 μs conversion time
 - Simultaneous sampling of two channels for motor control applications
 - Single-scan or continuous operation
 - Optional interrupts on conversion complete, zero crossing (sign change), or under/over low/high limit

Family Configurations

- Unused analog channels can be used as digital I/O
- Four 32-bit timers with DMA support
 - 12.5 ns resolution at 80 MHz
 - Programmable sources for clock input, including an external clock option
 - Programmable prescaler
 - Input capture capability with programmable trigger edge on input pin
 - Output compare with programmable mode for the output pin
 - Free run and restart modes
 - Maskable interrupts on input capture or output compare
 - DMA trigger capability on input capture or output compare
- Four-channel general purpose timer
 - 16-bit architecture
 - Programmable prescaler
 - Output pulse-widths variable from microseconds to seconds
 - Single 16-bit input pulse accumulator
 - Toggle-on-overflow feature for pulse-width modulator (PWM) generation
 - One dual-mode pulse accumulation channel
- Pulse-width modulation timer
 - Support for PCM mode (resulting in superior signal quality compared to conventional PWM)
 - Operates as eight channels with 8-bit resolution or four channels with 16-bit resolution
 - Programmable period and duty cycle
 - Programmable enable/disable for each channel
 - Software selectable polarity for each channel
 - Period and duty cycle are double buffered. Change takes effect when the end of the current period is reached (PWM counter reaches zero) or when the channel is disabled.
 - Programmable center or left aligned outputs on individual channels
 - Four clock sources (A, B, SA, and SB) provide for a wide range of frequencies
 - Emergency shutdown
- Two periodic interrupt timers (PITs)
 - 16-bit counter
 - Selectable as free running or count down
- Real-Time Clock (RTC)
 - Maintains system time-of-day clock
 - Provides stopwatch and alarm interrupt functions
 - Standby power supply (Vstby) keeps the RTC running when the system is shut down
- Software watchdog timer
 - 32-bit counter
 - Low-power mode support
- Backup watchdog timer (BWT)
 - Independent timer that can be used to help software recover from runaway code
 - 16-bit counter
 - Low-power mode support
- Clock generation features
 - Crystal, on-chip trimmed relaxation oscillator, or external oscillator reference options
 - Trimmed relaxation oscillator

- Pre-divider capable of dividing the clock source frequency into the PLL reference frequency range
- System can be clocked from PLL or directly from crystal oscillator or relaxation oscillator
- Low power modes supported
- 2^n ($0 \leq n \leq 15$) low-power divider for extremely low frequency operation
- Interrupt controller
 - Uniquely programmable vectors for all interrupt sources
 - Fully programmable level and priority for all peripheral interrupt sources
 - Seven external interrupt signals with fixed level and priority
 - Unique vector number for each interrupt source
 - Ability to mask any individual interrupt source or all interrupt sources (global mask-all)
 - Support for hardware and software interrupt acknowledge (IACK) cycles
 - Combinatorial path to provide wake-up from low-power modes
- DMA controller
 - Four fully programmable channels
 - Dual-address transfer support with 8-, 16-, and 32-bit data capability, along with support for 16-byte (4×32-bit) burst transfers
 - Source/destination address pointers that can increment or remain constant
 - 24-bit byte transfer counter per channel
 - Auto-alignment transfers supported for efficient block movement
 - Bursting and cycle-steal support
 - Software-programmable DMA requests for the UARTs (3) and 32-bit timers (4)
 - Channel linking support
- Reset
 - Separate reset in and reset out signals
 - Seven sources of reset:
 - Power-on reset (POR)
 - External
 - Software
 - Watchdog
 - Loss of clock / loss of lock
 - Low-voltage detection (LVD)
 - JTAG
 - Status flag indication of source of last reset
- Chip configuration module (CCM)
 - System configuration during reset
 - Selects one of six clock modes
 - Configures output pad drive strength
 - Unique part identification number and part revision number
- General purpose I/O interface
 - Up to 56 bits of general purpose I/O on 100-pin package
 - Up to 96 bits of general purpose I/O on 144-pin package
 - Bit manipulation supported via set/clear functions
 - Programmable drive strengths
 - Unused peripheral pins may be used as extra GPIO
- JTAG support for system level board testing

1.2.2 V2 Core Overview

The version 2 ColdFire processor core is comprised of two separate pipelines decoupled by an instruction buffer. The two-stage instruction fetch pipeline (IFP) is responsible for instruction-address generation and instruction fetch. The instruction buffer is a first-in-first-out (FIFO) buffer that holds prefetched instructions awaiting execution in the operand execution pipeline (OEP). The OEP includes two pipeline stages. The first stage decodes instructions and selects operands (DSOC); the second stage (AGEX) performs instruction execution and calculates operand effective addresses, if needed.

The V2 core implements the ColdFire instruction set architecture revision A+ with support for a separate user stack pointer register and four new instructions to assist in bit processing. Additionally, the core includes the enhanced multiply-accumulate (EMAC) unit for improved signal processing capabilities. The EMAC implements a three-stage arithmetic pipeline, optimized for 32x32 bit operations, with support for four 48-bit accumulators. Supported operands include 16- and 32-bit signed and unsigned integers, signed fractional operands, and a complete set of instructions to process these data types. The EMAC provides support for execution of DSP operations within the context of a single processor at a minimal hardware cost.

1.2.3 Integrated Debug Module

The ColdFire processor core debug interface is provided to support system debugging with low-cost debug and emulator development tools. Through a standard debug interface, access to debug information and real-time tracing capability is provided on 144-lead packages. This allows the processor and system to be debugged at full speed without the need for costly in-circuit emulators.

The on-chip breakpoint resources include a total of nine programmable 32-bit registers: an address and an address mask register, a data and a data mask register, four PC registers, and one PC mask register. These registers can be accessed through the dedicated debug serial communication channel or from the processor's supervisor mode programming model. The breakpoint registers can be configured to generate triggers by combining the address, data, and PC conditions in a variety of single- or dual-level definitions. The trigger event can be programmed to generate a processor halt or initiate a debug interrupt exception. This device implements revision B+ of the ColdFire Debug Architecture.

The processor's interrupt servicing options during emulator mode allow real-time critical interrupt service routines to be serviced while processing a debug interrupt event. This ensures the system continues to operate even during debugging.

To support program trace, the V2 debug module provides processor status (PST[3:0]) and debug data (DDATA[3:0]) ports. These buses and the PSTCLK output provide execution status, captured operand data, and branch target addresses defining processor activity at the CPU's clock rate. The device includes a new debug signal, ALLPST. This signal is the logical AND of the processor status (PST[3:0]) signals and is useful for detecting when the processor is in a halted state (PST[3:0] = 1111).

The full debug/trace interface is available only on the 144-pin packages. However, every product features the dedicated debug serial communication channel (DSI, DSO, DSCLK) and the ALLPST signal.

1.2.4 JTAG

The processor supports circuit board test strategies based on the Test Technology Committee of IEEE and the Joint Test Action Group (JTAG). The test logic includes a test access port (TAP) consisting of a 16-state controller, an instruction register, and three test registers (a 1-bit bypass register, a boundary-scan register, and a 32-bit ID register). The boundary scan register links the device's pins into one shift register. Test logic, implemented using static logic design, is independent of the device system logic.

The device implementation can:

- Perform boundary-scan operations to test circuit board electrical continuity
- Sample system pins during operation and transparently shift out the result in the boundary scan register
- Bypass the device for a given circuit board test by effectively reducing the boundary-scan register to a single bit
- Disable the output drive to pins during circuit-board testing
- Drive output pins to stable levels

1.2.5 On-Chip Memories

1.2.5.1 SRAM

The dual-ported SRAM module provides a general-purpose 64 KB memory block that the ColdFire core can access in a single cycle. The location of the memory block can be set to any 64 KB boundary within the 4 GB address space. This memory is ideal for storing critical code or data structures and for use as the system stack. Because the SRAM module is physically connected to the processor's high-speed local bus, it can quickly service core-initiated accesses or memory-referencing commands from the debug module.

The SRAM module is also accessible by the DMA, FEC, and USB. The dual-ported nature of the SRAM makes it ideal for implementing applications with double-buffer schemes, where the processor and a DMA device operate in alternate regions of the SRAM to maximize system performance.

1.2.5.2 Flash Memory

The ColdFire flash module (CFM) is a non-volatile memory (NVM) module that connects to the processor's high-speed local bus. The CFM is constructed with four banks of 64 KB×16-bit flash memory arrays to generate 512 KB of 32-bit flash memory. These electrically erasable and programmable arrays serve as non-volatile program and data memory. The flash memory is ideal for program and data storage for single-chip applications, allowing for field reprogramming without requiring an external high voltage source. The CFM interfaces to the ColdFire core through an optimized read-only memory controller that supports interleaved accesses from the 2-cycle flash memory arrays. A backdoor mapping of the flash memory is used for all program, erase, and verify operations, as well as providing a read datapath for the DMA. Flash memory may also be programmed via the EzPort, which is a serial flash memory programming interface that allows the flash memory to be read, erased and programmed by an external controller in a format compatible with most SPI bus flash memory chips.

1.2.6 Cryptographic Acceleration Unit

The MCF52235 device incorporates two hardware accelerators for cryptographic functions. First, the CAU is a coprocessor tightly-coupled to the V2 ColdFire core that implements a set of specialized operations to increase the throughput of software-based encryption and message digest functions, specifically the DES, 3DES, AES, MD5 and SHA-1 algorithms. Second, a random number generator provides FIPS-140 compliant 32-bit values to security processing routines. Both modules supply critical acceleration to software-based cryptographic algorithms at a minimal hardware cost.

1.2.7 Power Management

The device incorporates several low-power modes of operation entered under program control and exited by several external trigger events. An integrated power-on reset (POR) circuit monitors the input supply and forces an MCU reset as the supply voltage rises. The low voltage detector (LVD) monitors the supply voltage and is configurable to force a reset or interrupt condition if it falls below the LVD trip point. The RAM standby switch provides power to RAM when the supply voltage to the chip falls below the standby battery voltage.

1.2.8 FlexCAN

The FlexCAN module is a communication controller implementing version 2.0 of the CAN protocol parts A and B. The CAN protocol can be used as an industrial control serial data bus, meeting the specific requirements of reliable operation in a harsh EMI environment with high bandwidth. This instantiation of FlexCAN has 16 message buffers.

1.2.9 Mini-FlexBus

A multi-function external bus interface called the Mini-FlexBus is provided on the device with basic functionality of interfacing to slave-only devices with a maximum slave bus frequency up to 40 MHz in 1:2 mode and 80 MHz in 1:1 mode. It can be directly connected to the following asynchronous or synchronous devices with little or no additional circuitry:

- External ROMs
- Flash memories
- Programmable logic devices
- Other simple target (slave) devices

The Mini-FlexBus is a subset of the FlexBus module found on higher-end ColdFire microprocessors. The Mini-FlexBus minimizes package pin-outs while maintaining a high level of configurability and functionality.

1.2.10 USB On-The-Go Controller

The device includes a Universal Serial Bus On-The-Go (USB OTG) dual-mode controller. USB is a popular standard for connecting peripherals and portable consumer electronic devices such as digital cameras and handheld computers to host PCs. The OTG supplement to the USB specification extends USB to peer-to-peer application, enabling devices to connect directly to each other without the need for a PC. The dual-mode controller on the device can act as a USB OTG host and as a USB device. It also supports full-speed and low-speed modes.

1.2.11 Fast Ethernet Controller (FEC)

The Ethernet media access controller (MAC) supports 10 and 100 Mbps Ethernet/IEEE 802.3 networks. An external transceiver interface and transceiver function are required to complete the interface to the media. The FEC supports three different standard MAC-PHY (physical) interfaces for connection to an external Ethernet transceiver. The FECs supports the 10/100 Mbps MII, and the 10 Mbps-only 7-wire interface.

1.2.12 UARTs

The device has three full-duplex UARTs that function independently. The three UARTs can be clocked by the system bus clock, eliminating the need for an external clock source. On smaller packages, the third UART is multiplexed with other digital I/O functions.

1.2.13 I2C Bus

The processor includes two I2C modules. The I2C bus is an industry-standard, two-wire, bidirectional serial bus that provides a simple, efficient method of data exchange and minimizes the interconnection between devices. This bus is suitable for applications requiring occasional communications over a short distance between many devices.

1.2.14 QSPI

The queued serial peripheral interface (QSPI) provides a synchronous serial peripheral interface with queued transfer capability. It allows up to 16 transfers to be queued at once, minimizing the need for CPU intervention between transfers.

1.2.15 Fast ADC

The fast ADC consists of an eight-channel input select multiplexer and two independent sample and hold (S/H) circuits feeding separate 12-bit ADCs. The two separate converters store their results in accessible buffers for further processing. Signals on the SYNCA and SYNCA pins initiate an ADC conversion.

The ADC can be configured to perform a single scan and halt, a scan when triggered, or a programmed scan sequence repeatedly until manually stopped.

The ADC can be configured for sequential or simultaneous conversion. When configured for sequential conversions, up to eight channels can be sampled and stored in any order specified by the channel list register. Both ADCs may be required during a scan, depending on the inputs to be sampled.

During a simultaneous conversion, both S/H circuits are used to capture two different channels at the same time. This configuration requires that a single channel may not be sampled by both S/H circuits simultaneously.

Optional interrupts can be generated at the end of the scan sequence if a channel is out of range (measures below the low threshold limit or above the high threshold limit set in the limit registers) or at several different zero crossing conditions.

1.2.16 DMA Timers (DTIM0–DTIM3)

There are four independent, DMA transfer capable 32-bit timers (DTIM0, DTIM1, DTIM2, and DTIM3) on the device. Each module incorporates a 32-bit timer with a separate register set for configuration and control. The timers can be configured to operate from the system clock or from an external clock source using one of the DTIN n signals. If the system clock is selected, it can be divided by 16 or 1. The input clock is further divided by a user-programmable 8-bit prescaler that clocks the actual timer counter register (TCR n). Each of these timers can be configured for input capture or reference (output) compare mode. Timer events may optionally cause interrupt requests or DMA transfers.

1.2.17 General Purpose Timer (GPT)

The general purpose timer (GPT) is a four-channel timer module consisting of a 16-bit programmable counter driven by a seven-stage programmable prescaler. Each of the four channels can be configured for input capture or output compare. Additionally, channel three, can be configured as a pulse accumulator.

A timer overflow function allows software to extend the timing capability of the system beyond the 16-bit range of the counter. The input capture and output compare functions allow simultaneous input waveform measurements and output waveform generation. The input capture function can capture the time of a selected transition edge. The output compare function can generate output waveforms and timer software delays. The 16-bit pulse accumulator can operate as a simple event counter or a gated time accumulator.

1.2.18 Periodic Interrupt Timers (PIT0 and PIT1)

The two periodic interrupt timers (PIT0 and PIT1) are 16-bit timers that provide interrupts at regular intervals with minimal processor intervention. Each timer can count down from the value written in its PIT modulus register or it can be a free-running down-counter.

1.2.19 Real-Time Clock (RTC)

The Real-Time Clock (RTC) module maintains the system (time-of-day) clock and provides stopwatch, alarm, and interrupt functions. It includes full clock features: seconds, minutes, hours, days and supports a host of time-of-day interrupt functions along with an alarm interrupt.

1.2.20 Pulse-Width Modulation (PWM) Timers

The device has an 8-channel, 8-bit PWM timer. Each channel has a programmable period and duty cycle as well as a dedicated counter. Each of the modulators can create independent continuous waveforms with software-selectable duty rates from 0% to 100%. The timer supports PCM mode, which results in superior signal quality when compared to that of a conventional PWM. The PWM outputs have programmable polarity, and can be programmed as left aligned outputs or center aligned outputs. For

higher period and duty cycle resolution, each pair of adjacent channels ([7:6], [5:4], [3:2], and [1:0]) can be concatenated to form a single 16-bit channel. The module can, therefore, be configured to support 8/0, 6/1, 4/2, 2/3, or 0/4 8-/16-bit channels.

1.2.21 Software Watchdog Timer

The watchdog timer is a 32-bit timer that facilitates recovery from runaway code. The watchdog counter is a free-running down-counter that generates a reset on underflow. To prevent a reset, software must periodically restart the countdown.

1.2.22 Backup Watchdog Timer

The backup watchdog timer is an independent 16-bit timer that, like the software watchdog timer, facilitates recovery from runaway code. This timer is a free-running down-counter that generates a reset on underflow. To prevent a reset, software must periodically restart the countdown. The backup watchdog timer can be clocked by either the relaxation oscillator or the system clock.

1.2.23 Phase-Locked Loop (PLL)

The clock module contains a crystal oscillator, 8 MHz on-chip relaxation oscillator (OCO), phase-locked loop (PLL), reduced frequency divider (RFD), low-power divider status/control registers, and control logic. To improve noise immunity, the PLL, crystal oscillator, and relaxation oscillator have their own power supply inputs: VDDPLL and VSSPLL. All other circuits are powered by the normal supply pins, VDD and VSS.

1.2.24 Interrupt Controllers (INTC_n)

The device has two interrupt controllers that supports up to 128 interrupt sources. There are 56 programmable sources, 49 of which are assigned to unique peripheral interrupt requests. The remaining seven sources are unassigned and may be used for software interrupt requests.

1.2.25 DMA Controller

The direct memory access (DMA) controller provides an efficient way to move blocks of data with minimal processor intervention. It has four channels that allow byte, word, longword, or 16-byte burst line transfers. These transfers are triggered by software explicitly setting a DCR_n[START] bit or by the occurrence of certain UART or DMA timer events.

1.2.26 Reset

The reset controller determines the source of reset, asserts the appropriate reset signals to the system, and keeps track of what caused the last reset. There are seven sources of reset:

- External reset input
- Power-on reset (POR)
- Watchdog timer
- Phase locked-loop (PLL) loss of lock / loss of clock
- Software
- Low-voltage detector (LVD)
- JTAG

Control of the LVD and its associated reset and interrupt are managed by the reset controller. Other registers provide status flags indicating the last source of reset and a control bit for software assertion of the $\overline{\text{RSTO}}$ pin.

1.2.27 GPIO

Nearly all pins on the device have general purpose I/O capability and are grouped into 8-bit ports. Some ports do not use all eight bits. Each port has registers that configure, monitor, and control the port pin.

1.2.28 Part Numbers and Packaging

This product is RoHS-compliant. Refer to the product page at freescale.com or contact your sales office for up-to-date RoHS information.

Table 2. Orderable part number summary

| Freescle Part Number | FlexCAN | Encryption | Speed (MHz) | Flash (KB) | SRAM (KB) | Package | Temp range (°C) |
|----------------------|---------|------------|-------------|------------|-----------|------------|-----------------|
| MCF52252AF80 | — | — | 80 | 256 | 32 | 100 LQFP | 0 to +70 |
| MCF52252CAF66 | • | — | 66 | | | | -40 to +85 |
| MCF52254AF80 | — | — | 80 | 512 | 64 | 100 LQFP | 0 to +70 |
| MCF52254CAF66 | • | — | 66 | | | | -40 to +85 |
| MCF52255CAF80 | • | • | 80 | 512 | 64 | 100 LQFP | -40 to +85 |
| MCF52256AG80 | — | — | 80 | 256 | 32 | 144 LQFP | 0 to +70 |
| MCF52256CAG66 | • | — | 66 | | 64 | | -40 to +85 |
| MCF52256CVN66 | • | — | 66 | | 64 | 144 MAPBGA | -40 to +85 |
| MCF52256VN80 | — | — | 80 | | 32 | | 0 to +70 |
| MCF52258AG80 | — | — | 80 | 512 | 64 | 144 LQFP | 0 to +70 |
| MCF52258CAG66 | • | — | 66 | | | | -40 to +85 |
| MCF52258CVN66 | • | — | 66 | | | 144 MAPBGA | -40 to +85 |
| MCF52258VN80 | — | — | 80 | | | | 0 to +70 |
| MCF52259CAG80 | • | • | 80 | 512 | 64 | 144 LQFP | -40 to +85 |
| MCF52259CVN80 | • | • | | | | 144 MAPBGA | -40 to +85 |

Family Configurations

Figure 2 shows the pinout configuration for the 144 LQFP.

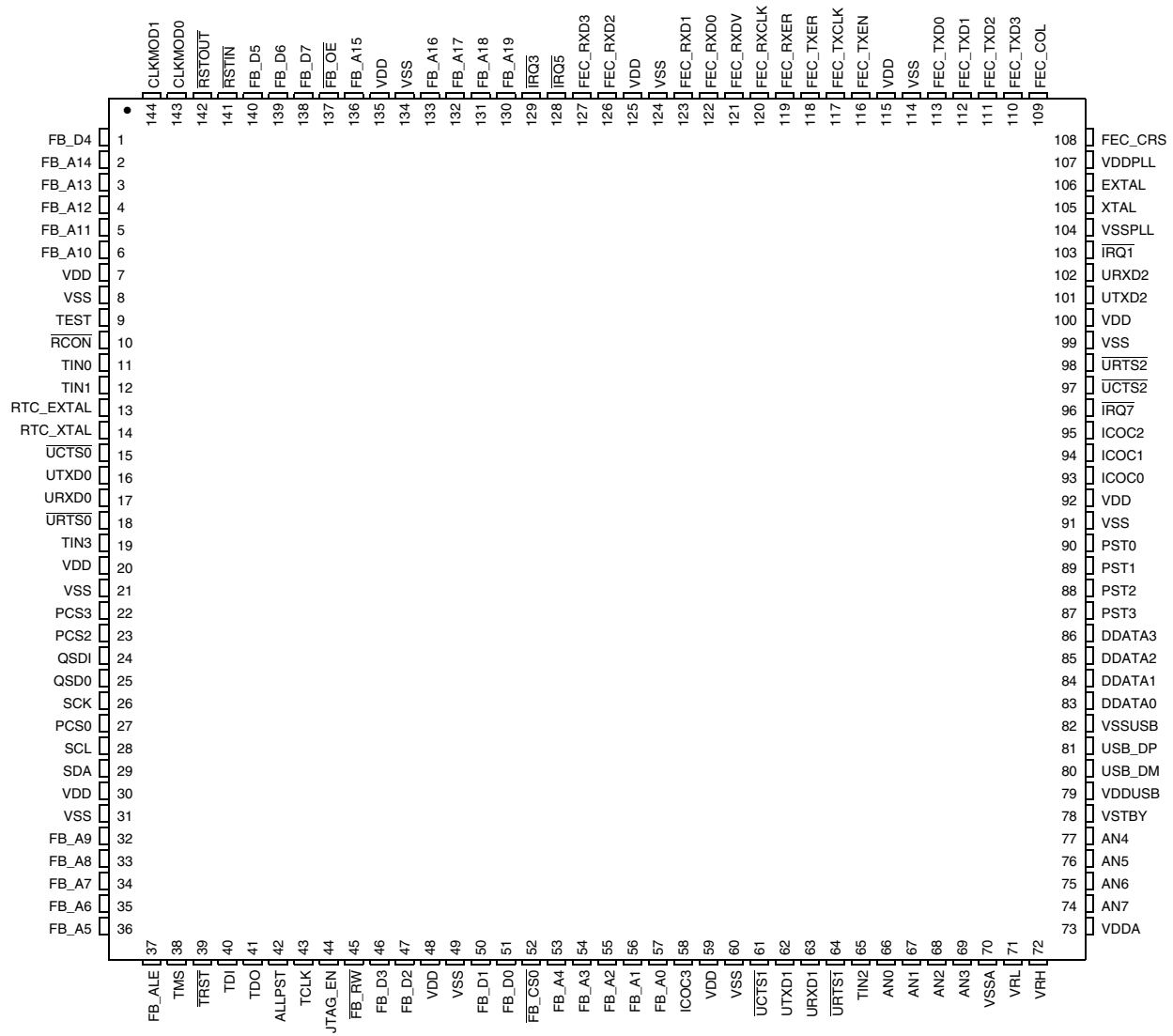

Figure 2. 144 LQFP Pin Assignment

Figure 3 shows the pinout configuration for the 100 LQFP.

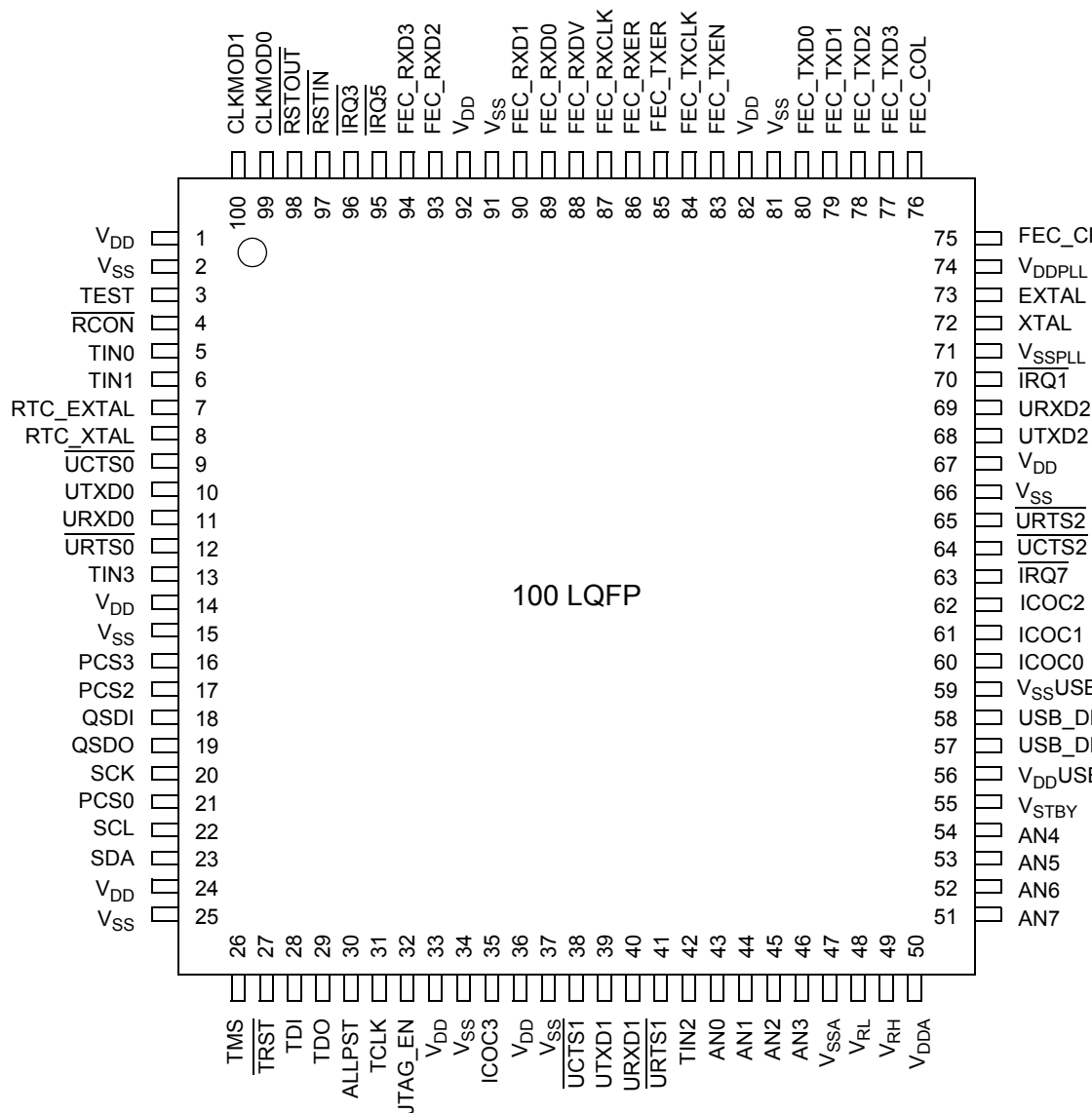

Figure 3. 100 LQFP Pin Assignments

Figure 4 shows the pinout configuration for the 144 MAPBGA.

| | 1 | 2 | 3 | 4 | 5 | 6 | 7 | 8 | 9 | 10 | 11 | |
|---|-----------|---------|--------|---------|---------|--------|----------|-----------|-----------|----------|----------|----|
| A | VSS | RSTOUT | RSTIN | FB_D6 | FB_D7 | IRQ3 | IRQ5 | FEC_RXD0 | FEC_RXER | FEC_TXEN | FEC_TXD3 | |
| B | TEST | FB_A14 | FB_D4 | FB_D5 | FB_OE | FB_A19 | FEC_RXD1 | FEC_RXCLK | FEC_TXCLK | FEC_TXD2 | FEC_COL | FE |
| C | TIN1 | FB_A12 | FB_A13 | FB_A15 | FB_A16 | FB_A18 | FEC_RXD2 | FEC_RXDV | FEC_TXD1 | URXD2 | VDDPLL | E |
| D | RTC_EXTAL | TIN0 | FB_A11 | CLKMOD1 | CLKMOD0 | FB_A17 | FEC_RXD3 | FEC_TXER | FEC_TXD0 | UTXD2 | VSSPLL | X |
| E | RTC_XTAL | UCTS0 | FB_A10 | RCON | VDD | VDD | VDD | VDD | IRQ1 | URTS2 | UCTS2 | I |
| F | UTXD0 | URXD0 | URTS0 | TIN3 | VDD | VSS | VSS | VSS | PST3 | DDATA0 | DDATA1 | IO |
| G | QSDO | QSDI | PCS2 | PCS3 | VDD | VSS | VSS | VSS | DDATA3 | PST2 | PST1 | F |
| H | SCL | SDA | SCK | PCS0 | VDD | VDD | VDD | VSS | VSSUSB | DDATA2 | USB_DM | US |
| J | FB_A6 | FB_A7 | FB_A9 | FB_A8 | FB_D0 | FB_A3 | VDD | TIN2 | VDDUSB | ICOC2 | ICOC1 | V |
| K | TMS | TRST | FB_ALE | FB_A5 | FB_D2 | FB_A4 | UCTS1 | UTXD1 | AN3 | AN6 | AN4 | |
| L | TDI | TDO | ALLPST | FB_D3 | FB_D1 | FB_A1 | FB_A0 | URXD1 | AN2 | VRH | VDDA | |
| M | VSS | JTAG_EN | TCLK | FB_RW | FB_CS0 | FB_A2 | ICOC3 | URTS1 | AN0 | AN1 | VRL | V |
| | 1 | 2 | 3 | 4 | 5 | 6 | 7 | 8 | 9 | 10 | 11 | |

Figure 4. Pinout Top View (144 MAPBGA)

Table 3 shows the pin functions by primary and alternate purpose, and illustrates which packages contain each pin.

Table 3. Pin Functions by Primary and Alternate Purpose

| Pin Group | Primary Function | Secondary Function (Alt 1) | Tertiary Function (Alt 2) | Quaternary Function (GPIO) | Slew Rate | Drive Strength/Control ¹ | Pull-up/Pull-down ² | Pin on 144 MAPBGA |
|------------------|------------------|----------------------------|---------------------------|----------------------------|-----------|-------------------------------------|--------------------------------|-------------------------------------|
| ADC | AN[7:0] | — | — | PAN[7:0] | Low | Low | — | L12, K10, K12, K11, K9, L9, M10, M9 |
| | VDDA | — | — | — | N/A | N/A | — | L11 |
| | VSSA | — | — | — | N/A | N/A | — | M12 |
| | VRH | — | — | — | N/A | N/A | — | L10 |
| | VRL | — | — | — | N/A | N/A | — | M11 |
| Clock Generation | EXTAL | — | — | — | N/A | N/A | — | C12 |
| | XTAL | — | — | — | N/A | N/A | — | D12 |
| | VDDPLL | — | — | — | N/A | N/A | — | C11 |
| | VSSPLL | — | — | — | N/A | N/A | — | D11 |
| RTC | RTC_EXTAL | — | — | — | N/A | N/A | — | D1 |
| | RTC_XTAL | — | — | — | N/A | N/A | — | E1 |
| Debug Data | ALLPST | — | — | — | Low | High | — | L3 |
| | DDATA[3:0] | — | — | PDD[7:4] | Low | High | — | G9, H10, F11, F10 |
| | PST[3:0] | — | — | PDD[3:0] | Low | High | — | F9, G10, G11, G12 |

Table 3. Pin Functions by Primary and Alternate Purpose (continued)

| Pin Group | Primary Function | Secondary Function (Alt 1) | Tertiary Function (Alt 2) | Quaternary Function (GPIO) | Slew Rate | Drive Strength/Control ¹ | Pull-up/ Pull-down ² | Pin on 144 MAPBGA |
|-------------------|---------------------------------|----------------------------|---------------------------|----------------------------|--------------|-------------------------------------|------------------------------------|-------------------|
| FEC | FEC_COL | — | — | PTI0 | PSRRH[0] | PDSRH[0] | — | B11 |
| | FEC_CRS | — | — | PTI1 | PSRRH[1] | PDSRH[1] | — | B12 |
| | FEC_RXCLK | — | — | PTI2 | PSRRH[2] | PDSRH[2] | — | B8 |
| | FEC_RXD[3:0] | — | — | PTI[6:3] | PSRRH[6:3] | PDSRH[6:3] | — | D7, C7, B7, A8 |
| | FEC_RXDV | — | — | PTI7 | PSRRH[7] | PDSRH[7] | — | C8 |
| | FEC_RXER | — | — | PTJ0 | PSRRH[8] | PDSRH[8] | — | A9 |
| | FEC_TXCLK | — | — | PTJ1 | PSRRH[9] | PDSRH[9] | — | B9 |
| FEC_TXD[3:0] | — | — | PTJ[5:2] | PSRRH[13:10] | PDSRH[13:10] | — | A11, B10, C9, D9 | |
| FEC | FEC_TXEN | — | — | PTJ6 | PSRRH[14] | PDSRH[14] | — | A10 |
| | FEC_TXER | — | — | PTJ7 | PSRRH[15] | PDSRH[15] | — | D8 |
| I2C0 ³ | I2C_SCL0 | — | UTXD2 | PAS0 | PSRR[0] | PDSR[0] | Pull-Up ⁴ | H1 |
| | I2C_SDA0 | — | URXD2 | PAS1 | PSRR[0] | PDSR[0] | Pull-Up ⁴ | H2 |
| Interrupts | IRQ7 | — | — | PNQ7 | Low | Low | Pull-Up ⁴ | E12 |
| | IRQ5 | FEC_MDC | — | PNQ5 | Low | Low | Pull-Up ⁴ | A7 |
| | IRQ3 | FEC_MDIO | — | PNQ3 | Low | Low | Pull-Up ⁴ | A6 |
| | IRQ1 | — | USB_ALT CLK | PNQ1 | Low | High | Pull-Up ⁴ | E9 |
| JTAG/BDM | JTAG_EN | — | — | — | N/A | N/A | Pull-Down | M2 |
| | TCLK/ PSTCLK/ CLKOUT | — | FB_CLK | — | Low | Low | Pull-Up ⁵ | M3 |
| | TDI/DSI | — | — | — | N/A | N/A | Pull-Up ⁵ | L1 |
| | TDO/DSO | — | — | — | Low | Low | — | L2 |
| | TMS/ $\overline{\text{BKPT}}$ | — | — | — | N/A | N/A | Pull-Up ⁵ | K1 |
| | $\overline{\text{TRST}}$ /DSCLK | — | — | — | N/A | N/A | Pull-Up ⁵ | K2 |

Table 3. Pin Functions by Primary and Alternate Purpose (continued)

| Pin Group | Primary Function | Secondary Function (Alt 1) | Tertiary Function (Alt 2) | Quaternary Function (GPIO) | Slew Rate | Drive Strength/Control ¹ | Pull-up/Pull-down ² | Pin on 144 MAPBGA |
|--------------------|--------------------------|----------------------------|---------------------------|----------------------------|-----------|-------------------------------------|--------------------------------|-------------------|
| Mode Selection | RCON/EZPCS | — | — | — | N/A | N/A | Pull-Up | E4 |
| | CLKMOD[1:0] | — | — | — | N/A | N/A | Pull-Down | D4, D5 |
| QSPI | QSPI_CS3 | SYNCA | USB_DP_PDOWN | PQS6 | PSRR[7] | PDSR[7] | — | G4 |
| | QSPI_CS2 | SYNCB | USB_DM_PDOWN | PQS5 | PSRR[6] | PDSR[6] | — | G3 |
| | QSPI_CS0 | I2C_SDA0 | UCTS1 | PQS3 | PSRR[4] | PDSR[4] | Pull-Up ⁶ | H4 |
| | QSPI_CLK/EZPCK | I2C_SCL0 | URTS1 | PQS2 | PSRR[3] | PDSR[3] | Pull-Up ⁶ | H3 |
| QSPI | QSPI_DIN/EZPD | I2C_SDA1 | URXD1 | PQS1 | PSRR[2] | PDSR[2] | Pull-Up ⁶ | G2 |
| | QSPI_DOUT/EZPQ | I2C_SCL1 | UTXD1 | PQS0 | PSRR[1] | PDSR[1] | Pull-Up ⁶ | G1 |
| Reset ⁷ | $\overline{\text{RSTI}}$ | — | — | — | N/A | N/A | Pull-Up ⁷ | A3 |
| | $\overline{\text{RSTO}}$ | — | — | — | Low | High | — | A2 |
| Test | TEST | — | — | — | N/A | N/A | Pull-Down | B1 |
| Timer 3, 16-bit | GPT3 | — | PWM7 | PTA3 | PSRR[23] | PDSR[23] | Pull-Up ⁸ | M7 |
| Timer 2, 16-bit | GPT2 | — | PWM5 | PTA2 | PSRR[22] | PDSR[22] | Pull-Up ⁸ | J10 |
| Timer 1, 16-bit | GPT1 | — | PWM3 | PTA1 | PSRR[21] | PDSR[21] | Pull-Up ⁸ | J11 |
| Timer 0, 16-bit | GPT0 | — | PWM1 | PTA0 | PSRR[20] | PDSR[20] | Pull-Up ⁸ | F12 |
| Timer 3, 32-bit | DTIN3 | DTOUT3 | PWM6 | PTC3 | PSRR[19] | PDSR[19] | — | F4 |
| Timer 2, 32-bit | DTIN2 | DTOUT2 | PWM4 | PTC2 | PSRR[18] | PDSR[18] | — | J8 |

Table 3. Pin Functions by Primary and Alternate Purpose (continued)

| Pin Group | Primary Function | Secondary Function (Alt 1) | Tertiary Function (Alt 2) | Quaternary Function (GPIO) | Slew Rate | Drive Strength/Control ¹ | Pull-up/Pull-down ² | Pin on 144 MAPBGA |
|-----------------|------------------|----------------------------|---------------------------|----------------------------|-----------|-------------------------------------|--------------------------------|-------------------|
| Timer 1, 32-bit | DTIN1 | DTOUT1 | PWM2 | PTC1 | PSRR[17] | PDSR[17] | — | C1 |
| Timer 0, 32-bit | DTIN0 | DTOUT0 | PWM0 | PTC0 | PSRR[16] | PDSR[16] | — | D2 |
| UART 0 | UCTS0 | — | USB_VBUS | PUA3 | PSRR[11] | PDSR[11] | — | E2 |
| | URTS0 | — | USB_VBUS | PUA2 | PSRR[10] | PDSR[10] | — | F3 |
| | URXD0 | — | — | PUA1 | PSRR[9] | PDSR[9] | — | F2 |
| | UTXD0 | — | — | PUA0 | PSRR[8] | PDSR[8] | — | F1 |
| UART 1 | UCTS1 | SYNCA | URXD2 | PUB3 | PSRR[15] | PDSR[15] | — | K7 |
| | URTS1 | SYNCB | UTXD2 | PUB2 | PSRR[14] | PDSR[14] | — | M8 |
| | URXD1 | I2C_SDA1 | — | PUB1 | PSRR[13] | PDSR[13] | Pull-Up ⁶ | L8 |
| | UTXD1 | I2C_SCL1 | — | PUB0 | PSRR[12] | PDSR[12] | Pull-Up ⁶ | K8 |
| UART 2 | UCTS2 | I2C_SCL1 | USB_VBUSCHG | PUC3 | PSRR[27] | PDSR[27] | Pull-Up ⁶ | E11 |
| | URTS2 | I2C_SDA1 | USB_VBUSDIS | PUC2 | PSRR[26] | PDSR[26] | Pull-Up ⁶ | E10 |
| | URXD2 | CANRX | — | PUC1 | PSRR[25] | PDSR[25] | — | C10 |
| | UTXD2 | CANTX | — | PUC0 | PSRR[24] | PDSR[24] | — | D10 |
| USB OTG | USB_DM | — | — | — | N/A | N/A | — | H11 |
| | USB_DP | — | — | — | N/A | N/A | — | H12 |
| | USB_VDD | — | — | — | N/A | N/A | — | J9 |
| | USB_VSS | — | — | — | N/A | N/A | — | H9 |

Table 3. Pin Functions by Primary and Alternate Purpose (continued)

| Pin Group | Primary Function | Secondary Function (Alt 1) | Tertiary Function (Alt 2) | Quaternary Function (GPIO) | Slew Rate | Drive Strength/Control ¹ | Pull-up/Pull-down ² | Pin on 144 MAPBGA |
|---------------------------|-----------------------------|-----------------------------|---------------------------|----------------------------|--------------|-------------------------------------|--------------------------------|--------------------------------|
| Mini-FlexBus ⁹ | FB_ALE | $\overline{\text{FB_CS1}}$ | — | PAS2 | PSRRL[20] | PDSRL[20] | — | K3 |
| | FB_AD[7:0] | — | — | PTE[7:0] | PSRRL[7:0] | PDSRL[7:0] | — | J2, J1, K4, K6, J6, M6, L6, L7 |
| | FB_AD[15:8] | — | — | PTF[7:0] | PSRRL[15:8] | PDSRL[15:8] | — | C4, B2, C3, C2, D3, E3, J3, J4 |
| | FB_AD[19:16] | — | — | PTG[3:0] | PSRRL[19:16] | PDSRL[19:16] | — | B6, C6, D6, C5 |
| | $\overline{\text{FB_CS0}}$ | — | — | PTG5 | PSRRL[21] | PDSRL[21] | — | M5 |
| | $\overline{\text{FB_R/W}}$ | — | — | PTG7 | PSRRL[31] | PDSRL[31] | — | M4 |
| | $\overline{\text{FB_OE}}$ | — | — | PTG6 | PSRRL[30] | PDSRL[30] | — | B5 |
| | FB_D7 | CANRX | — | PTH5 | PSRRL[29] | PDSRL[29] | — | A5 |
| | FB_D6 | CANTX | — | PTH4 | PSRRL[28] | PDSRL[28] | — | A4 |
| | FB_D5 | I2C_SCL1 | — | PTH3 | PSRRL[27] | PDSRL[27] | Pull-Up ⁶ | B4 |
| | FB_D4 | I2C_SDA1 | — | PTH2 | PSRRL[26] | PDSRL[26] | Pull-Up ⁶ | B3 |
| | FB_D3 | USB_VBUS _D | — | PTH1 | PSRRL[25] | PDSRL[25] | — | L4 |
| | FB_D2 | USB_VBU _S E | — | PTH0 | PSRRL[24] | PDSRL[24] | — | K5 |
| | FB_D1 | SYNCA | — | PTH7 | PSRRL[23] | PDSRL[23] | — | L5 |
| FB_D0 | SYNCB | — | PTH6 | PSRRL[22] | PDSRL[22] | — | J5 | |
| Standby Voltage | VSTBY | — | — | — | N/A | N/A | — | J12 |
| VDD ¹⁰ | VDD | — | — | — | N/A | N/A | — | E5–E8; F5; G5; H5–7; J7 |

Table 3. Pin Functions by Primary and Alternate Purpose (continued)

| Pin Group | Primary Function | Secondary Function (Alt 1) | Tertiary Function (Alt 2) | Quaternary Function (GPIO) | Slew Rate | Drive Strength/Control ¹ | Pull-up/Pull-down ² | Pin on 144 MAPBGA |
|-----------|------------------|----------------------------|---------------------------|----------------------------|-----------|-------------------------------------|--------------------------------|-----------------------------|
| VSS | VSS | — | — | — | N/A | N/A | — | A1; A12; F6–8; G6–8; H8; M1 |

- ¹ The PDSR and PSSR registers are part of the GPIO module. All programmable signals default to 2mA drive in normal (single-c
- ² All signals have a pull-up in GPIO mode.
- ³ I2C1 is multiplexed with specific pins of the QSPI, UART1, UART2, and Mini-FlexBus pin groups.
- ⁴ For primary and GPIO functions only.
- ⁵ Only when JTAG mode is enabled.
- ⁶ For secondary and GPIO functions only.
- ⁷ RSTI has an internal pull-up resistor; however, the use of an external resistor is strongly recommended.
- ⁸ For GPIO functions, the Primary Function has pull-up control within the GPT module.
- ⁹ Available on 144-pin packages only.
- ¹⁰ This list for power and ground does not include those dedicated power/ground pins included elsewhere, such as in the ADC, US

2 Electrical Characteristics

This section contains electrical specification tables and reference timing diagrams for the microcontroller unit, including detailed information on power considerations, DC/AC electrical characteristics, and AC timing specifications.

NOTE

The parameters specified in this data sheet supersede any values found in the module specifications.

2.1 Maximum Ratings

Table 4. Absolute Maximum Ratings^{1, 2}

| Rating | Symbol | Value | Unit |
|---|--------------------------|--------------------------------------|------|
| Supply voltage | V_{DD} | -0.3 to +4.0 | V |
| Clock synthesizer supply voltage | V_{DDPLL} | -0.3 to +4.0 | V |
| RAM standby supply voltage | V_{STBY} | +1.8 to 3.5 | V |
| USB standby supply voltage | V_{DDUSB} | -0.3 to +4.0 | V |
| Digital input voltage ³ | V_{IN} | -0.3 to +4.0 | V |
| EXTAL pin voltage | V_{EXTAL} | 0 to 3.3 | V |
| XTAL pin voltage | V_{XTAL} | 0 to 3.3 | V |
| Instantaneous maximum current Single pin limit (applies to all pins) ^{4, 5} | I_{DD} | 25 | mA |
| Operating temperature range (packaged) | T_A ($T_L - T_H$) | -40 to 85 or 0 to 70 ⁶ | °C |
| Storage temperature range | T_{stg} | -65 to 150 | °C |

¹ Functional operating conditions are given in DC Electrical Specifications. Absolute Maximum Ratings are stress ratings only, and functional operation at the maxima is not guaranteed. Stress beyond those listed may affect device reliability or cause permanent damage to the device.

² This device contains circuitry protecting against damage due to high static voltage or electrical fields; however, it is advised that normal precautions be taken to avoid application of any voltages higher than maximum-rated voltages to this high-impedance circuit. Reliability of operation is enhanced if unused inputs are tied to an appropriate logic voltage level (V_{SS} or V_{DD}).

³ Input must be current limited to the I_{DD} value specified. To determine the value of the required current-limiting resistor, calculate resistance values for positive and negative clamp voltages, then use the larger of the two values.

⁴ All functional non-supply pins are internally clamped to V_{SS} and V_{DD} .

⁵ The power supply must maintain regulation within operating V_{DD} range during instantaneous and operating maximum current conditions. If positive injection current ($V_{in} > V_{DD}$) is greater than I_{DD} , the injection current may flow out of V_{DD} and could result in the external power supply going out of regulation. Ensure that the external V_{DD} load shunts current greater than maximum injection current. This is the greatest risk when the MCU is not consuming power (e.g., no clock).

⁶ Depending on the packaging; see orderable part number summary (Table 2)

2.2 Current Consumption

Table 5. Typical Active Current Consumption Specifications

| Characteristic | Symbol | Typical ¹ Active (SRAM) | Typical ¹ Active (Flash) | Peak ² (Flash) | Unit |
|---|--------------------|--|---|------------------------------|----------|
| PLL @ 8 MHz | I _{DD} | 22 | 30 | 36 | mA |
| PLL @ 16 MHz | | 31 | 45 | 60 | |
| PLL @ 64 MHz | | 84 | 100 | 155 | |
| PLL @ 80 MHz | | 102 | 118 | 185 | |
| RAM standby supply current • Normal operation: V _{DD} > V _{STBY} - 0.3 V • Standby operation: V _{DD} < V _{SS} + 0.5 V | I _{STBY} | — | — | 5 20 | μA μA |
| Analog supply current • Normal operation | I _{DDA} | 2 ³ | | 15 | mA |
| USB supply current | I _{DDUSB} | — | | 2 | mA |
| PLL supply current | I _{DDPLL} | — | | 6 ⁴ | mA |

¹ Tested at room temperature with CPU polling a status register. All clocks were off except the UART and CFM (when running from flash memory).

² Peak current measured with all modules active, CPU polling a status register, and default drive strength with matching load.

³ Tested using Auto Power Down (APD), which powers down the ADC between conversions; ADC running at 4 MHz in Once Parallel mode with a sample rate of 3 kHz.

⁴ Tested with the PLL MFD set to 7 (max value). Setting the MFD to a lower value results in lower current consumption.

Table 6. Current Consumption in Low-Power Mode, Code From Flash Memory^{1,2,3}

| Mode | 8 MHz (Typ) | 16 MHz (Typ) | 64 MHz (Typ) | 80 MHz (Typ) | Unit | Symbol |
|--------------------------------------|-------------|--------------|--------------|--------------|------|-----------------|
| Stop mode 3 (Stop 11) ⁴ | 0.150 | | | | mA | I _{DD} |
| Stop mode 2 (Stop 10) ⁴ | 7.0 | | | | | |
| Stop mode 1 (Stop 01) ^{4,5} | 9 | 10 | 15 | 17 | | |
| Stop mode 0 (Stop 00) ⁵ | 9 | 10 | 15 | 17 | | |
| Wait / Doze | 21 | 32 | 56 | 65 | | |
| Run | 23 | 36 | 70 | 81 | | |

¹ All values are measured with a 3.30 V power supply. Tests performed at room temperature.

² Refer to the Power Management chapter in the *MCF52259 Reference Manual* for more information on low-power modes.

³ CLKOUT, PST/DDATA signals, and all peripheral clocks except UART0 and CFM off before entering low-power mode. CLKOUT is disabled.

⁴ See the description of the Low-Power Control Register (LPCR) in the *MCF52259 Reference Manual* for more information on stop modes 0–3.

⁵ Results are identical to STOP 00 for typical values because they only differ by CLKOUT power consumption. CLKOUT is already disabled in this instance prior to entering low-power mode.

Table 7. Current Consumption in Low-Power Mode, Code From SRAM^{1,2,3}

| Mode | 8 MHz (Typ) | 16 MHz (Typ) | 64 MHz (Typ) | 80 MHz (Typ) | Unit | Symbol |
|--------------------------------------|-------------|--------------|--------------|--------------|------|-----------------|
| Stop mode 3 (Stop 11) ⁴ | 0.090 | | | | mA | I _{DD} |
| Stop mode 2 (Stop 10) ⁴ | 7 | | | | | |
| Stop mode 1 (Stop 01) ^{4,5} | 9 | 10 | 15 | 17 | | |
| Stop mode 0 (Stop 00) ⁵ | 9 | 10 | 15 | 17 | | |
| Wait / Doze | 13 | 18 | 42 | 50 | | |
| Run | 16 | 21 | 55 | 65 | | |

¹ All values are measured with a 3.3 V power supply. Tests performed at room temperature.

² Refer to the Power Management chapter in the *MCF52259 Reference Manual* for more information on low-power modes.

³ CLKOUT, PST/DDATA signals, and all peripheral clocks except UART0 off before entering low-power mode. CLKOUT is disabled. Code executed from SRAM with flash memory shut off by writing 0x0 to the FLASHBAR register.

⁴ See the description of the Low-Power Control Register (LPCR) in the *MCF52259 Reference Manual* for more information on stop modes 0–3.

⁵ Results are identical to STOP 00 for typical values because they only differ by CLKOUT power consumption. CLKOUT is already disabled in this instance prior to entering low-power mode.

2.3 Thermal Characteristics

Table 8 lists thermal resistance values.

Table 8. Thermal Characteristics

| | Characteristic | | Symbol | Value | Unit |
|------------|---|-------------------------|----------------|-------------------|------|
| 144 MAPBGA | Junction to ambient, natural convection | Single layer board (1s) | θ_{JA} | 53 ^{1,2} | °C/W |
| | Junction to ambient, natural convection | Four layer board (2s2p) | θ_{JA} | 30 ^{1,3} | °C/W |
| | Junction to ambient, (@200 ft/min) | Single layer board (1s) | θ_{JMA} | 43 ^{1,3} | °C/W |
| | Junction to ambient, (@200 ft/min) | Four layer board (2s2p) | θ_{JMA} | 26 ^{1,3} | °C/W |
| | Junction to board | — | θ_{JB} | 16 ⁴ | °C/W |
| | Junction to case | — | θ_{JC} | 9 ⁵ | °C/W |
| | Junction to top of package | Natural convection | Ψ_{jt} | 2 ⁶ | °C/W |
| | Maximum operating junction temperature | — | T_j | 105 | °C |
| 144 LQFP | Junction to ambient, natural convection | Single layer board (1s) | θ_{JA} | 44 ^{7,8} | °C/W |
| | Junction to ambient, natural convection | Four layer board (2s2p) | θ_{JA} | 35 ^{1,9} | °C/W |
| | Junction to ambient, (@200 ft/min) | Single layer board (1s) | θ_{JMA} | 35 ^{1,3} | °C/W |
| | Junction to ambient, (@200 ft/min) | Four layer board (2s2p) | θ_{JMA} | 29 ^{1,3} | °C/W |
| | Junction to board | — | θ_{JB} | 23 ¹⁰ | °C/W |
| | Junction to case | — | θ_{JC} | 7 ¹¹ | °C/W |
| | Junction to top of package | Natural convection | Ψ_{jt} | 2 ¹² | °C/W |
| | Maximum operating junction temperature | — | T_j | 105 | °C |

Table 8. Thermal Characteristics (continued)

| | Characteristic | | Symbol | Value | Unit |
|----------|---|-------------------------|----------------|---------------------|------|
| 100 LQFP | Junction to ambient, natural convection | Single layer board (1s) | θ_{JA} | 53 ^{13,14} | °C/W |
| | Junction to ambient, natural convection | Four layer board (2s2p) | θ_{JA} | 39 ^{1,15} | °C/W |
| | Junction to ambient, (@200 ft/min) | Single layer board (1s) | θ_{JMA} | 42 ^{1,3} | °C/W |
| | Junction to ambient, (@200 ft/min) | Four layer board (2s2p) | θ_{JMA} | 33 ^{1,3} | °C/W |
| | Junction to board | — | θ_{JB} | 25 ¹⁶ | °C/W |
| | Junction to case | — | θ_{JC} | 9 ¹⁷ | °C/W |
| | Junction to top of package | Natural convection | Ψ_{jt} | 2 ¹⁸ | °C/W |
| | Maximum operating junction temperature | — | T_j | 105 | °C |

¹ θ_{JA} and Ψ_{jt} parameters are simulated in conformance with EIA/JESD Standard 51-2 for natural convection. Freescale recommends the use of θ_{JA} and power dissipation specifications in the system design to prevent device junction temperatures from exceeding the rated specification. System designers should be aware that device junction temperatures can be significantly influenced by board layout and surrounding devices. Conformance to the device junction temperature specification can be verified by physical measurement in the customer's system using the Ψ_{jt} parameter, the device power dissipation, and the method described in EIA/JESD Standard 51-2.

² Per JEDEC JESD51-2 with the single-layer board (JESD51-3) horizontal.

³ Per JEDEC JESD51-6 with the board JESD51-7) horizontal.

⁴ Thermal resistance between the die and the printed circuit board in conformance with JEDEC JESD51-8. Board temperature is measured on the top surface of the board near the package.

⁵ Thermal resistance between the die and the case top surface as measured by the cold plate method (MIL SPEC-883 Method 1012.1).

⁶ Thermal characterization parameter indicating the temperature difference between package top and the junction temperature per JEDEC JESD51-2. When Greek letters are not available, the thermal characterization parameter is written in conformance with Psi-JT.

⁷ θ_{JA} and Ψ_{jt} parameters are simulated in conformance with EIA/JESD Standard 51-2 for natural convection. Freescale recommends the use of θ_{JA} and power dissipation specifications in the system design to prevent device junction temperatures from exceeding the rated specification. System designers should be aware that device junction temperatures can be significantly influenced by board layout and surrounding devices. Conformance to the device junction temperature specification can be verified by physical measurement in the customer's system using the Ψ_{jt} parameter, the device power dissipation, and the method described in EIA/JESD Standard 51-2.

⁸ Per JEDEC JESD51-2 with the single-layer board (JESD51-3) horizontal.

⁹ Per JEDEC JESD51-6 with the board JESD51-7) horizontal.

¹⁰ Thermal resistance between the die and the printed circuit board in conformance with JEDEC JESD51-8. Board temperature is measured on the top surface of the board near the package.

¹¹ Thermal resistance between the die and the case top surface as measured by the cold plate method (MIL SPEC-883 Method 1012.1).

¹² Thermal characterization parameter indicating the temperature difference between package top and the junction temperature per JEDEC JESD51-2. When Greek letters are not available, the thermal characterization parameter is written in conformance with Psi-JT.

¹³ θ_{JA} and Ψ_{jt} parameters are simulated in conformance with EIA/JESD Standard 51-2 for natural convection. Freescale recommends the use of θ_{JA} and power dissipation specifications in the system design to prevent device junction temperatures from exceeding the rated specification. System designers should be aware that device junction temperatures can be significantly influenced by board layout and surrounding devices. Conformance to the device junction temperature specification can be verified by physical measurement in the customer's system using the Ψ_{jt} parameter, the device power dissipation, and the method described in EIA/JESD Standard 51-2.

¹⁴ Per JEDEC JESD51-2 with the single-layer board (JESD51-3) horizontal.

¹⁵ Per JEDEC JESD51-6 with the board JESD51-7) horizontal.

- ¹⁶ Thermal resistance between the die and the printed circuit board in conformance with JEDEC JESD51-8. Board temperature is measured on the top surface of the board near the package.
- ¹⁷ Thermal resistance between the die and the case top surface as measured by the cold plate method (MIL SPEC-883 Method 1012.1).
- ¹⁸ Thermal characterization parameter indicating the temperature difference between package top and the junction temperature per JEDEC JESD51-2. When Greek letters are not available, the thermal characterization parameter is written in conformance with Psi-JT.

The average chip-junction temperature (T_J) in °C can be obtained from:

$$T_J = T_A + (P_D \times \Theta_{JMA}) \quad (1)$$

Where:

- T_A = ambient temperature, °C
 Θ_{JA} = package thermal resistance, junction-to-ambient, °C/W
 P_D = $P_{INT} + P_{I/O}$
 P_{INT} = chip internal power, $I_{DD} \times V_{DD}$, W
 $P_{I/O}$ = power dissipation on input and output pins — user determined, W

For most applications $P_{I/O} < P_{INT}$ and can be ignored. An approximate relationship between P_D and T_J (if $P_{I/O}$ is neglected) is:

$$P_D = K \div (T_J + 273^\circ\text{C}) \quad (2)$$

Solving equations 1 and 2 for K gives:

$$K = P_D \times (T_A + 273^\circ\text{C}) + \Theta_{JMA} \times P_D^2 \quad (3)$$

where K is a constant pertaining to the particular part. K can be determined from equation (3) by measuring P_D (at equilibrium) for a known T_A . Using this value of K, the values of P_D and T_J can be obtained by solving equations (1) and (2) iteratively for any value of T_A .

2.4 Flash Memory Characteristics

The flash memory characteristics are shown in [Table 9](#) and [Table 10](#).

Table 9. SGFM Flash Program and Erase Characteristics

($V_{DD} = 3.0$ to 3.6 V)

| Parameter | Symbol | Min | Typ | Max | Unit |
|---|-----------------------|------|-----|--------------------------|------|
| System clock (read only) | $f_{\text{sys}(R)}$ | 0 | — | 66.67 or 80 ¹ | MHz |
| System clock (program/erase) ² | $f_{\text{sys}(P/E)}$ | 0.15 | — | 66.67 or 80 ¹ | MHz |

¹ Depending on packaging; see the orderable part number summary ([Table 2](#)).

² Refer to the flash memory section for more information ([Section 2.4, “Flash Memory Characteristics”](#))

Table 10. SGFM Flash Module Life Characteristics

($V_{DD} = 3.0$ to 3.6 V)

| Parameter | Symbol | Value | Unit |
|---|-----------|---------------------|--------|
| Maximum number of guaranteed program/erase cycles ¹ before failure | P/E | 10,000 ² | Cycles |
| Data retention at average operating temperature of 85°C | Retention | 10 | Years |

¹ A program/erase cycle is defined as switching the bits from 1 → 0 → 1.

Electrical Characteristics

² Reprogramming of a flash memory array block prior to erase is not required.

2.5 EzPort Electrical Specifications

Table 11. EzPort Electrical Specifications

| Name | Characteristic | Min | Max | Unit |
|------|--|---------------------------|----------------------|------|
| EP1 | EPCK frequency of operation (all commands except READ) | — | $f_{\text{sys}} / 2$ | MHz |
| EP1a | EPCK frequency of operation (READ command) | — | $f_{\text{sys}} / 8$ | MHz |
| EP2 | EPCS_b negation to next EPCS_b assertion | $2 \times T_{\text{cyc}}$ | — | ns |
| EP3 | EPCS_B input valid to EPCK high (setup) | 5 | — | ns |
| EP4 | EPCK high to EPCS_B input invalid (hold) | 5 | — | ns |
| EP5 | EPD input valid to EPCK high (setup) | 2 | — | ns |
| EP6 | EPCK high to EPD input invalid (hold) | 5 | — | ns |
| EP7 | EPCK low to EPQ output valid (out setup) | — | 12 | ns |
| EP8 | EPCK low to EPQ output invalid (out hold) | 0 | — | ns |
| EP9 | EPCS_B negation to EPQ tri-state | — | 12 | ns |

2.6 ESD Protection

Table 12. ESD Protection Characteristics^{1, 2}

| Characteristics | Symbol | Value | Units |
|---------------------------------|---------------------|-------|----------|
| ESD target for Human Body Model | HBM | 2000 | V |
| ESD target for Machine Model | MM | 200 | V |
| HBM circuit description | R_{series} | 1500 | Ω |
| | C | 100 | pF |
| MM circuit description | R_{series} | 0 | Ω |
| | C | 200 | pF |
| Number of pulses per pin (HBM) | | | — |
| • Positive pulses | — | 1 | |
| • Negative pulses | — | 1 | |
| Number of pulses per pin (MM) | | | — |
| • Positive pulses | — | 3 | |
| • Negative pulses | — | 3 | |
| Interval of pulses | — | 1 | sec |

¹ All ESD testing is in conformity with CDF-AEC-Q100 Stress Test Qualification for Automotive Grade Integrated Circuits.

² A device is defined as a failure if after exposure to ESD pulses the device no longer meets the device specification requirements. Complete DC parametric and functional testing is performed per applicable device specification at room temperature followed by hot temperature, unless specified otherwise in the device specification.

2.7 DC Electrical Specifications

Table 13. DC Electrical Specifications ¹

| Characteristic | Symbol | Min | Max | Unit |
|--|--------------|----------------------|----------------------|---------|
| Supply voltage | V_{DD} | 3.0 | 3.6 | V |
| Standby voltage | V_{STBY} | 1.8 | 3.5 | V |
| Input high voltage | V_{IH} | $0.7 \times V_{DD}$ | 4.0 | V |
| Input low voltage | V_{IL} | $V_{SS} - 0.3$ | $0.35 \times V_{DD}$ | V |
| Input hysteresis ² | V_{HYS} | $0.06 \times V_{DD}$ | — | mV |
| Low-voltage detect trip voltage (V_{DD} falling) | V_{LVD} | 2.15 | 2.3 | V |
| Low-voltage detect hysteresis (V_{DD} rising) | V_{LVDHYS} | 60 | 120 | mV |
| Input leakage current $V_{in} = V_{DD}$ or V_{SS} , digital pins | I_{in} | -1.0 | 1.0 | μ A |
| Output high voltage (all input/output and all output pins) $I_{OH} = -2.0$ mA | V_{OH} | $V_{DD} - 0.5$ | — | V |
| Output low voltage (all input/output and all output pins) $I_{OL} = 2.0$ mA | V_{OL} | — | 0.5 | V |
| Output high voltage (high drive) $I_{OH} = -5$ mA | V_{OH} | $V_{DD} - 0.5$ | — | V |
| Output low voltage (high drive) $I_{OL} = 5$ mA | V_{OL} | — | 0.5 | V |
| Output high voltage (low drive) $I_{OH} = -2$ mA | V_{OH} | $V_{DD} - 0.5$ | — | V |
| Output low voltage (low drive) $I_{OL} = 2$ mA | V_{OL} | — | 0.5 | V |
| Weak internal pull Up device current, tested at V_{IL} Max. ³ | I_{APU} | -10 | -130 | μ A |
| Input Capacitance ⁴ • All input-only pins • All input/output (three-state) pins | C_{in} | — | 7 | pF |

¹ Refer to Table 14 for additional PLL specifications.

² Only for pins: IRQ1, IRQ3, IRQ5, IRQ7, RSTIN_B, TEST, RCON_B, PCS0, SCK, I2C_SDA, I2C_SCL, TCLK, TRST_B

³ Refer to Table 3 for pins having internal pull-up devices.

⁴ This parameter is characterized before qualification rather than 100% tested.

2.8 Clock Source Electrical Specifications

Table 14. Oscillator and PLL Specifications

(V_{DD} and $V_{DDPLL} = 3.0$ to 3.6 V, $V_{SS} = V_{SSPLL} = 0$ V)

| Characteristic | Symbol | Min | Max | Unit |
|--|----------------------------|---------------------|--|-------------|
| Clock Source Frequency Range of EXTAL Frequency Range • Crystal • External ¹ | $f_{crystal}$ f_{ext} | 12 0 | 25.0 ² 66.67 or 80 | MHz |
| PLL reference frequency range | f_{ref_pll} | 2 | 10.0 | MHz |
| System frequency ³ • External clock mode • On-chip PLL frequency | f_{sys} | 0 $f_{ref} / 32$ | 66.67 or 80 ⁴ 66.67 or 80 ⁴ | MHz |
| Loss of reference frequency ^{5, 7} | f_{LOR} | 100 | 1000 | kHz |
| Self clocked mode frequency ⁶ | f_{SCM} | 1 | 5 | MHz |
| Crystal start-up time ^{7, 8} | t_{cst} | — | 0.1 | ms |
| EXTAL input high voltage • External reference | V_{IHEXT} | 2.0 | 3.0 ² | V |
| EXTAL input low voltage • External reference | V_{ILEXT} | V_{SS} | 0.8 | V |
| PLL lock time ^{4,9} | t_{lpll} | — | 500 | μ s |
| Duty cycle of reference ⁴ | t_{dc} | 40 | 60 | % f_{ref} |
| Frequency un-LOCK range | f_{UL} | -1.5 | 1.5 | % f_{ref} |
| Frequency LOCK range | f_{LCK} | -0.75 | 0.75 | % f_{ref} |
| CLKOUT period jitter ^{4, 5, 10, 11} , measured at f_{SYS} Max • Peak-to-peak (clock edge to clock edge) • Long term (averaged over 2 ms interval) | C_{jitter} | — — | 10 .01 | % f_{sys} |
| On-chip oscillator frequency | f_{oco} | 7.84 | 8.16 | MHz |

¹ In external clock mode, it is possible to run the chip directly from an external clock source without enabling the PLL.

² This value has been updated.

³ All internal registers retain data at 0 Hz.

⁴ Depending on packaging; see the orderable part number summary (Table 2).

⁵ Loss of Reference Frequency is the reference frequency detected internally, which transitions the PLL into self clocked mode.

⁶ Self clocked mode frequency is the frequency at which the PLL operates when the reference frequency falls below f_{LOR} with default MFD/RFD settings.

⁷ This parameter is characterized before qualification rather than 100% tested.

⁸ Proper PC board layout procedures must be followed to achieve specifications.

⁹ This specification applies to the period required for the PLL to relock after changing the MFD frequency control bits in the synthesizer control register (SYNCR).

¹⁰ Jitter is the average deviation from the programmed frequency measured over the specified interval at maximum f_{sys} . Measurements are made with the device powered by filtered supplies and clocked by a stable external clock signal. Noise injected into the PLL circuitry via V_{DDPLL} and V_{SSPLL} and variation in crystal oscillator frequency increase the C_{jitter} percentage for a given interval.

¹¹ Based on slow system clock of 40 MHz measured at f_{sys} max.

2.9 USB Operation

Table 15. USB Operation Specifications

| Characteristic | Symbol | Value | Unit |
|--------------------------------------|----------------------------|-------|------|
| Minimum core speed for USB operation | $f_{\text{sys_USB_min}}$ | 16 | MHz |

2.10 Mini-FlexBus External Interface Specifications

A multi-function external bus interface called Mini-FlexBus is provided with basic functionality to interface to slave-only devices up to a maximum bus frequency of 80 MHz. It can be directly connected to asynchronous or synchronous devices such as external boot ROMs, flash memories, gate-array logic, or other simple target (slave) devices with little or no additional circuitry. For asynchronous devices a simple chip-select based interface can be used.

All processor bus timings are synchronous; that is, input setup/hold and output delay are given in respect to the rising edge of a reference clock, MB_CLK. The MB_CLK frequency is half the internal system bus frequency.

The following timing numbers indicate when data is latched or driven onto the external bus, relative to the Mini-FlexBus output clock (MB_CLK). All other timing relationships can be derived from these values.

Table 16. Mini-FlexBus AC Timing Specifications

| Num | Characteristic | Min | Max | Unit | Notes |
|-----|------------------------|------|-----|------|--------------|
| | Frequency of Operation | — | 80 | MHz | |
| MB1 | Clock Period | 12.5 | — | ns | |
| MB2 | Output Valid | — | 8 | ns | ¹ |
| MB3 | Output Hold | 2 | — | ns | ¹ |
| MB4 | Input Setup | 6 | — | ns | ² |
| MB5 | Input Hold | 0 | — | ns | ² |

¹ Specification is valid for all MB_A[19:0], MB_D[7:0], MB_CS[1:0], MB_OE, MB_R/W, and MB_ALE.

² Specification is valid for all MB_D[7:0].

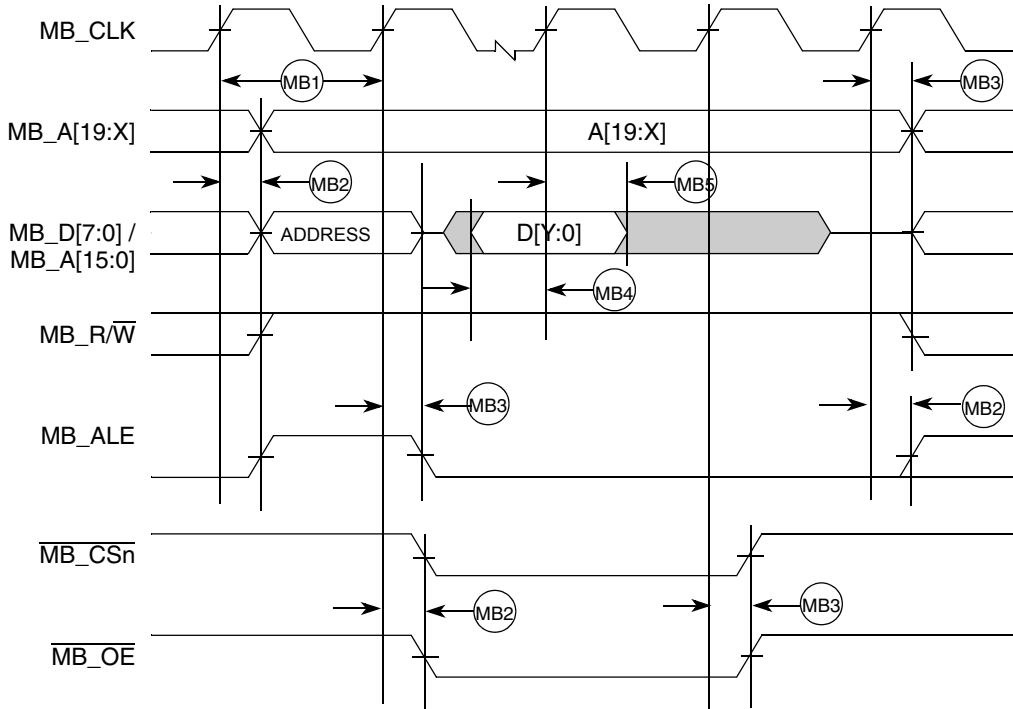

Figure 5. Mini-FlexBus Read Timing

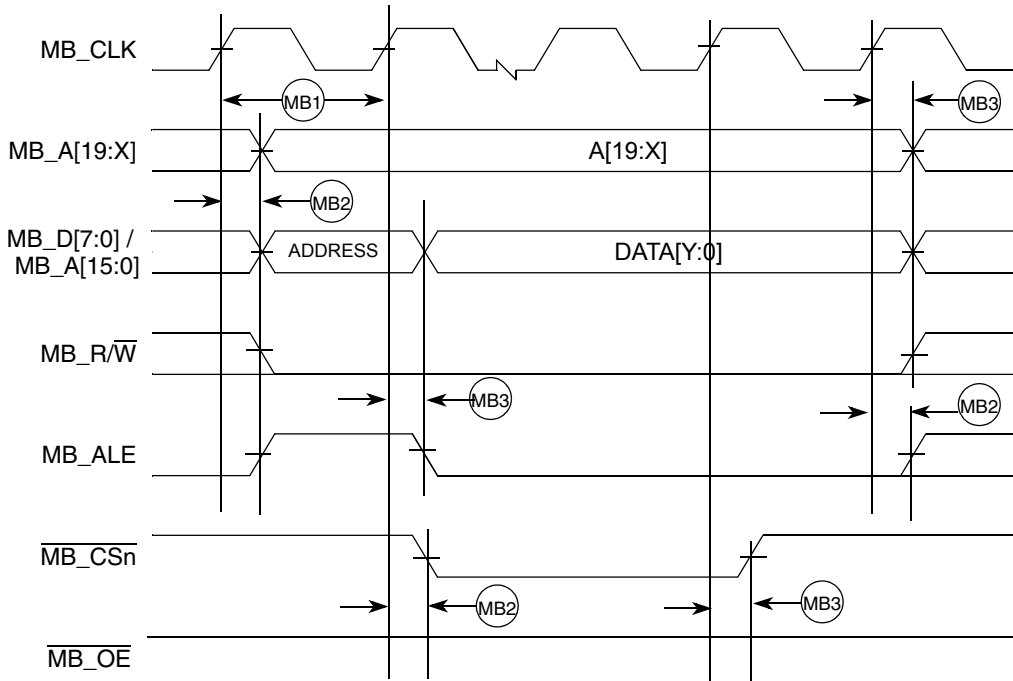

Figure 6. Mini-FlexBus Write Timing

2.11 Fast Ethernet Timing Specifications

The following timing specs are defined at the chip I/O pin and must be translated appropriately to arrive at timing specs/constraints for the physical interface.

2.11.1 Receive Signal Timing Specifications

The following timing specs meet the requirements for MII and 7-Wire style interfaces for a range of transceiver devices.

Table 17. Receive Signal Timing

| Num | Characteristic | MII Mode | | Unit |
|-----|--|----------|-----|--------------|
| | | Min | Max | |
| — | RXCLK frequency | — | 25 | MHz |
| E1 | RXD[n:0], RXDV, RXER to RXCLK setup ¹ | 5 | — | ns |
| E2 | RXCLK to RXD[n:0], RXDV, RXER hold ¹ | 5 | — | ns |
| E3 | RXCLK pulse width high | 35% | 65% | RXCLK period |
| E4 | RXCLK pulse width low | 35% | 65% | RXCLK period |

¹ In MII mode, n = 3

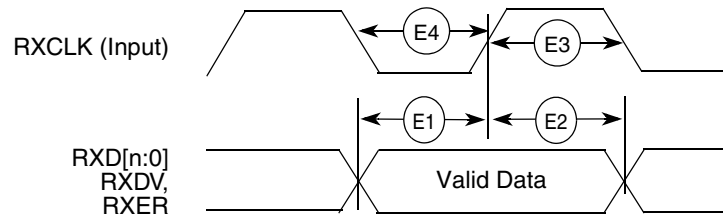

Figure 7. MII Receive Signal Timing Diagram

2.11.2 Transmit Signal Timing Specifications

Table 18. Transmit Signal Timing

| Num | Characteristic | MII Mode | | Unit |
|-----|--|----------|-----|-------------|
| | | Min | Max | |
| — | TXCLK frequency | — | 25 | MHz |
| E5 | TXCLK to TXD[n:0], TXEN, TXER invalid ¹ | 5 | — | ns |
| E6 | TXCLK to TXD[n:0], TXEN, TXER valid ¹ | — | 25 | ns |
| E7 | TXCLK pulse width high | 35% | 65% | t_{TXCLK} |
| E8 | TXCLK pulse width low | 35% | 65% | t_{TXCLK} |

¹ In MII mode, n = 3

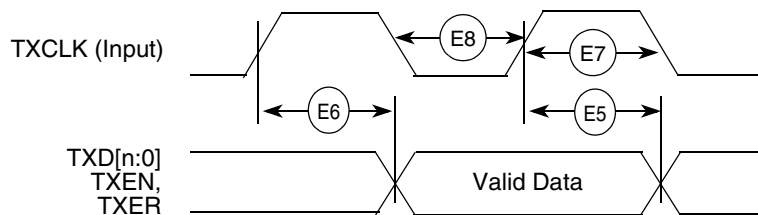

Figure 8. MII Transmit Signal Timing Diagram

2.11.3 Asynchronous Input Signal Timing Specifications

Table 19. MII Transmit Signal Timing

| Num | Characteristic | Min | Max | Unit |
|-----|------------------------------|-----|-----|--------------|
| E9 | CRS, COL minimum pulse width | 1.5 | — | TXCLK period |

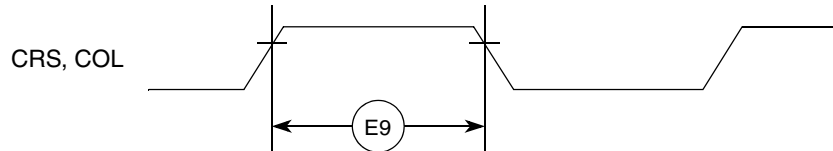

Figure 9. MII Async Inputs Timing Diagram

2.11.4 MII Serial Management Timing Specifications

Table 20. MII Serial Management Channel Signal Timing

| Num | Characteristic | Symbol | Min | Max | Unit |
|-----|----------------------------|-----------|-----|-----|-------------|
| E10 | MDC cycle time | t_{MDC} | 400 | — | ns |
| E11 | MDC pulse width | | 40 | 60 | % t_{MDC} |
| E12 | MDC to MDIO output valid | | — | 375 | ns |
| E13 | MDC to MDIO output invalid | | 25 | — | ns |
| E14 | MDIO input to MDC setup | | 10 | — | ns |
| E15 | MDIO input to MDC hold | | 0 | — | ns |

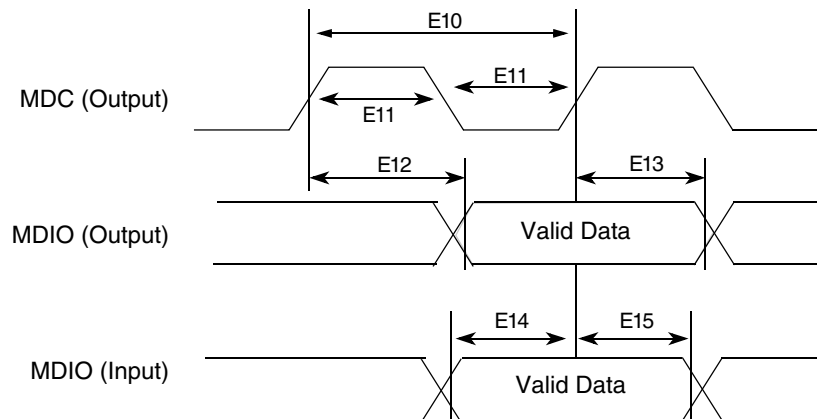

Figure 10. MII Serial Management Channel Timing Diagram

2.12 General Purpose I/O Timing

GPIO can be configured for certain pins of the QSPI, DDR Control, timer, UART, Interrupt and USB interfaces. When in GPIO mode, the timing specification for these pins is given in [Table 21](#) and [Figure 11](#).

The GPIO timing is met under the following load test conditions:

- 50 pF / 50 Ω for high drive

- 25 pF / 25 Ω for low drive

Table 21. GPIO Timing

| NUM | Characteristic | Symbol | Min | Max | Unit |
|-----|------------------------------------|-------------|-----|-----|------|
| G1 | CLKOUT High to GPIO Output Valid | t_{CHPOV} | — | 10 | ns |
| G2 | CLKOUT High to GPIO Output Invalid | t_{CHPOI} | 1.5 | — | ns |
| G3 | GPIO Input Valid to CLKOUT High | t_{PVCH} | 9 | — | ns |
| G4 | CLKOUT High to GPIO Input Invalid | t_{CHPI} | 1.5 | — | ns |

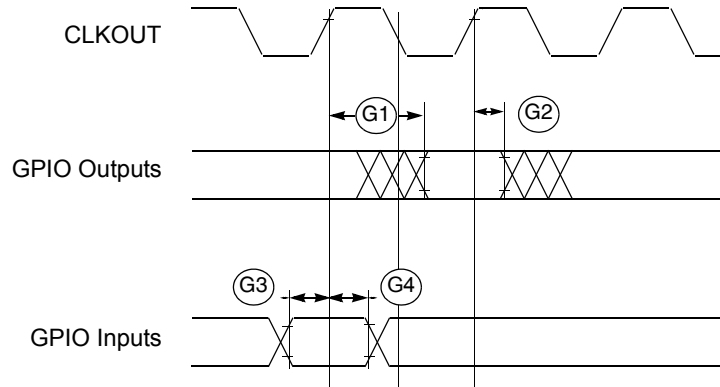

Figure 11. GPIO Timing

2.13 Reset Timing

Table 22. Reset and Configuration Override Timing

($V_{DD} = 3.0$ to 3.6 V, $V_{SS} = 0$ V, $T_A = T_L$ to T_H)¹

| NUM | Characteristic | Symbol | Min | Max | Unit |
|-----|---|-------------|-----|-----|-----------|
| R1 | \overline{RSTI} input valid to CLKOUT High | t_{RVCH} | 9 | — | ns |
| R2 | CLKOUT High to \overline{RSTI} Input invalid | t_{CHRI} | 1.5 | — | ns |
| R3 | \overline{RSTI} input valid time ² | t_{RIVT} | 5 | — | t_{CYC} |
| R4 | CLKOUT High to \overline{RSTO} Valid | t_{CHROV} | — | 10 | ns |

¹ All AC timing is shown with respect to 50% V_{DD} levels unless otherwise noted.

² During low power STOP, the synchronizers for the \overline{RSTI} input are bypassed and \overline{RSTI} is asserted asynchronously to the system. Thus, \overline{RSTI} must be held a minimum of 100 ns.

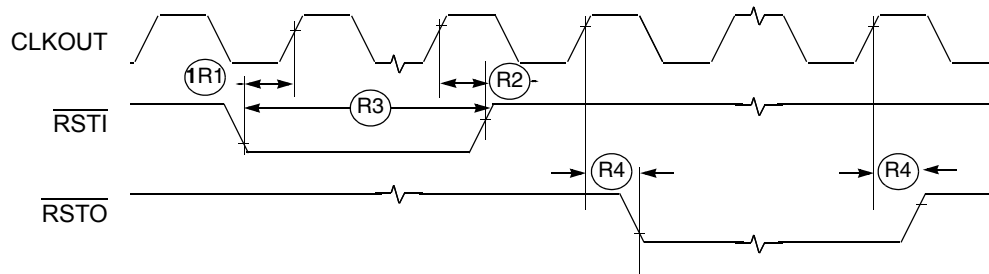
Figure 12. \overline{RSTI} and Configuration Override Timing

2.14 I2C Input/Output Timing Specifications

Table 23 lists specifications for the I2C input timing parameters shown in Figure 13.

Table 23. I2C Input Timing Specifications between I2C_SCL and I2C_SDA

| Num | Characteristic | Min | Max | Units |
|-----|--|--------------------|-----|-------|
| I1 | Start condition hold time | $2 \times t_{CYC}$ | — | ns |
| I2 | Clock low period | $8 \times t_{CYC}$ | — | ns |
| I3 | SCL/SDA rise time ($V_{IL} = 0.5 \text{ V}$ to $V_{IH} = 2.4 \text{ V}$) | — | 1 | ms |
| I4 | Data hold time | 0 | — | ns |
| I5 | SCL/SDA fall time ($V_{IH} = 2.4 \text{ V}$ to $V_{IL} = 0.5 \text{ V}$) | — | 1 | ms |
| I6 | Clock high time | $4 \times t_{CYC}$ | — | ns |
| I7 | Data setup time | 0 | — | ns |
| I8 | Start condition setup time (for repeated start condition only) | $2 \times t_{CYC}$ | — | ns |
| I9 | Stop condition setup time | $2 \times t_{CYC}$ | — | ns |

Table 24 lists specifications for the I2C output timing parameters shown in Figure 13.

Table 24. I2C Output Timing Specifications between I2C_SCL and I2C_SDA

| Num | Characteristic | Min | Max | Units |
|-----------------|---|---------------------|-----|---------------|
| I1 ¹ | Start condition hold time | $6 \times t_{CYC}$ | — | ns |
| I2 ¹ | Clock low period | $10 \times t_{CYC}$ | — | ns |
| I3 ² | I2C_SCL/I2C_SDA rise time ($V_{IL} = 0.5 \text{ V}$ to $V_{IH} = 2.4 \text{ V}$) | — | — | μs |
| I4 ¹ | Data hold time | $7 \times t_{CYC}$ | — | ns |
| I5 ³ | I2C_SCL/I2C_SDA fall time ($V_{IH} = 2.4 \text{ V}$ to $V_{IL} = 0.5 \text{ V}$) | — | 3 | ns |
| I6 ¹ | Clock high time | $10 \times t_{CYC}$ | — | ns |
| I7 ¹ | Data setup time | $2 \times t_{CYC}$ | — | ns |
| I8 ¹ | Start condition setup time (for repeated start condition only) | $20 \times t_{CYC}$ | — | ns |
| I9 ¹ | Stop condition setup time | $10 \times t_{CYC}$ | — | ns |

¹ Output numbers depend on the value programmed into the IFDR; an IFDR programmed with the maximum frequency (IFDR = 0x20) results in minimum output timings as shown in Table 24. The I²C interface is designed to scale the actual data transition time to move it to the middle of the SCL low period. The actual position is affected by the prescale and division values programmed into the IFDR; however, the numbers given in Table 24 are minimum values.

² Because SCL and SDA are open-collector-type outputs, which the processor can only actively drive low, the time SCL or SDA take to reach a high level depends on external signal capacitance and pull-up resistor values.

³ Specified at a nominal 50 pF load.

Figure 13 shows timing for the values in Table 23 and Table 24.

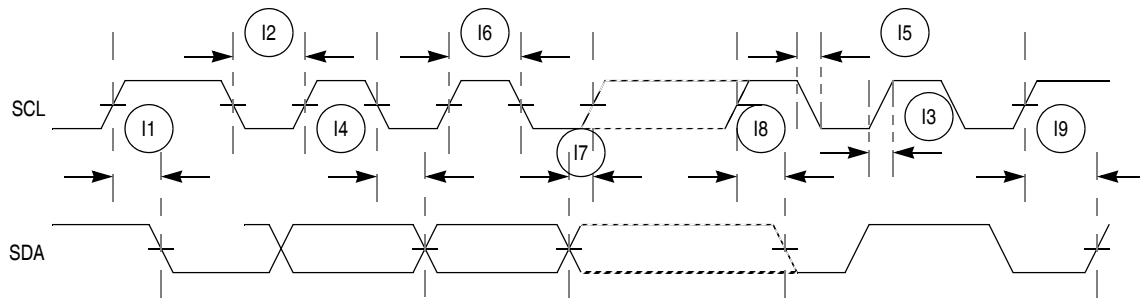

Figure 13. I2C Input/Output Timings

2.15 Analog-to-Digital Converter (ADC) Parameters

Table 25 lists specifications for the analog-to-digital converter.

Table 25. ADC Parameters¹

| Name | Characteristic | Min | Typical | Max | Unit |
|---------------------|---|--------------------------|---------------|--------------------------|--------------------------------------|
| V _{REFL} | Low reference voltage | V _{SSA} | — | V _{SSA} + 50 mV | V |
| V _{REFH} | High reference voltage | V _{DDA} - 50 mV | — | V _{DDA} | V |
| V _{DDA} | ADC analog supply voltage | 3.1 | 3.3 | 3.6 | V |
| V _{ADIN} | Input voltages | V _{REFL} | — | V _{REFH} | V |
| RES | Resolution | 12 | — | 12 | Bits |
| INL | Integral non-linearity (full input signal range) ² | — | ±2.5 | ±3 | LSB ³ |
| INL | Integral non-linearity (10% to 90% input signal range) ⁴ | — | ±2.5 | ±3 | LSB |
| DNL | Differential non-linearity | — | -1 < DNL < +1 | <+1 | LSB |
| Monotonicity | | GUARANTEED | | | |
| f _{ADIC} | ADC internal clock | 0.1 | — | 5.0 | MHz |
| R _{AD} | Conversion range | V _{REFL} | — | V _{REFH} | V |
| t _{ADPU} | ADC power-up time ⁵ | — | 6 | 13 | t _{AIC} cycles ⁶ |
| t _{REC} | Recovery from auto standby | — | 0 | 1 | t _{AIC} cycles |
| t _{ADC} | Conversion time | — | 6 | — | t _{AIC} cycles |
| t _{ADS} | Sample time | — | 1 | — | t _{AIC} cycles |
| C _{ADI} | Input capacitance | — | See Figure 14 | — | pF |
| X _{IN} | Input impedance | — | See Figure 14 | — | W |
| I _{ADI} | Input injection current ⁷ , per pin | — | — | 3 | mA |
| I _{VREFH} | V _{REFH} current | — | 0 | — | mA |
| V _{OFFSET} | Offset voltage internal reference | — | ±8 | ±15 | mV |
| E _{GAIN} | Gain error (transfer path) | .99 | 1 | 1.01 | — |
| V _{OFFSET} | Offset voltage external reference | — | ±3 | 9 | mV |

Table 25. ADC Parameters¹ (continued)

| Name | Characteristic | Min | Typical | Max | Unit |
|-------|---------------------------------|-----|------------|-----|------|
| SNR | Signal-to-noise ratio | — | 62 to 66 | — | dB |
| THD | Total harmonic distortion | — | -75 | — | dB |
| SFDR | Spurious free dynamic range | — | 67 to 70.3 | — | dB |
| SINAD | Signal-to-noise plus distortion | — | 61 to 63.9 | — | dB |
| ENOB | Effective number of bits | 9.1 | 10.6 | — | Bits |

¹ All measurements are preliminary pending full characterization, and made at $V_{DD} = 3.3\text{ V}$, $V_{REFH} = 3.3\text{ V}$, and $V_{REFL} = \text{ground}$

² INL measured from $V_{IN} = V_{REFL}$ to $V_{IN} = V_{REFH}$

³ LSB = Least Significant Bit

⁴ INL measured from $V_{IN} = 0.1V_{REFH}$ to $V_{IN} = 0.9V_{REFH}$

⁵ Includes power-up of ADC and V_{REF}

⁶ ADC clock cycles

⁷ Current that can be injected or sourced from an unselected ADC signal input without impacting the performance of the ADC

2.16 Equivalent Circuit for ADC Inputs

Figure 14 shows the ADC input circuit during sample and hold. S1 and S2 are always open/closed at the same time that S3 is closed/open. When S1/S2 are closed and S3 is open, one input of the sample and hold circuit moves to $(V_{REFH} - V_{REFL})/2$, while the other charges to the analog input voltage. When the switches are flipped, the charge on C1 and C2 are averaged via S3, with the result that a single-ended analog input is switched to a differential voltage centered about $(V_{REFH} - V_{REFL})/2$. The switches switch on every cycle of the ADC clock (open one-half ADC clock, closed one-half ADC clock). There are additional capacitances associated with the analog input pad, routing, etc., but these do not filter into the S/H output voltage, as S1 provides isolation during the charge-sharing phase. One aspect of this circuit is that there is an on-going input current, which is a function of the analog input voltage, V_{REF} and the ADC clock frequency.

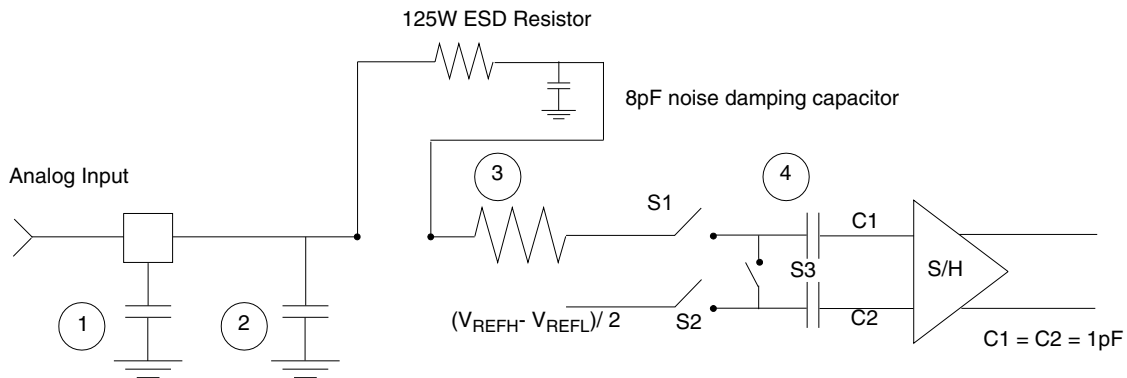

1. Parasitic capacitance due to package, pin-to-pin and pin-to-package base coupling; 1.8 pF
2. Parasitic capacitance due to the chip bond pad, ESD protection devices and signal routing; 2.04 pF
3. Equivalent resistance for the channel select mux; 100 Ω
4. Sampling capacitor at the sample and hold circuit. Capacitor C1 is normally disconnected from the input and is only connected to it at sampling time; 1.4 pF
5. Equivalent input impedance, when the input is selected =
$$\frac{1}{(\text{ADC Clock Rate}) \times (1.4 \times 10^{-12})}$$

Figure 14. Equivalent Circuit for A/D Loading

2.17 DMA Timers Timing Specifications

Table 26 lists timer module AC timings.

Table 26. Timer Module AC Timing Specifications

| Name | Characteristic ¹ | Min | Max | Unit |
|------|---|--------------------|-----|------|
| T1 | DTIN0 / DTIN1 / DTIN2 / DTIN3 cycle time | $3 \times t_{CYC}$ | — | ns |
| T2 | DTIN0 / DTIN1 / DTIN2 / DTIN3 pulse width | $1 \times t_{CYC}$ | — | ns |

¹ All timing references to CLKOUT are given to its rising edge.

2.18 QSPI Electrical Specifications

Table 27 lists QSPI timings.

Table 27. QSPI Modules AC Timing Specifications

| Name | Characteristic | Min | Max | Unit |
|------|--|-----|-----|-----------|
| QS1 | QSPI_CS[3:0] to QSPI_CLK | 1 | 510 | t_{CYC} |
| QS2 | QSPI_CLK high to QSPI_DOUT valid | — | 10 | ns |
| QS3 | QSPI_CLK high to QSPI_DOUT invalid (Output hold) | 2 | — | ns |
| QS4 | QSPI_DIN to QSPI_CLK (Input setup) | 9 | — | ns |
| QS5 | QSPI_DIN to QSPI_CLK (Input hold) | 9 | — | ns |

The values in Table 27 correspond to Figure 15.

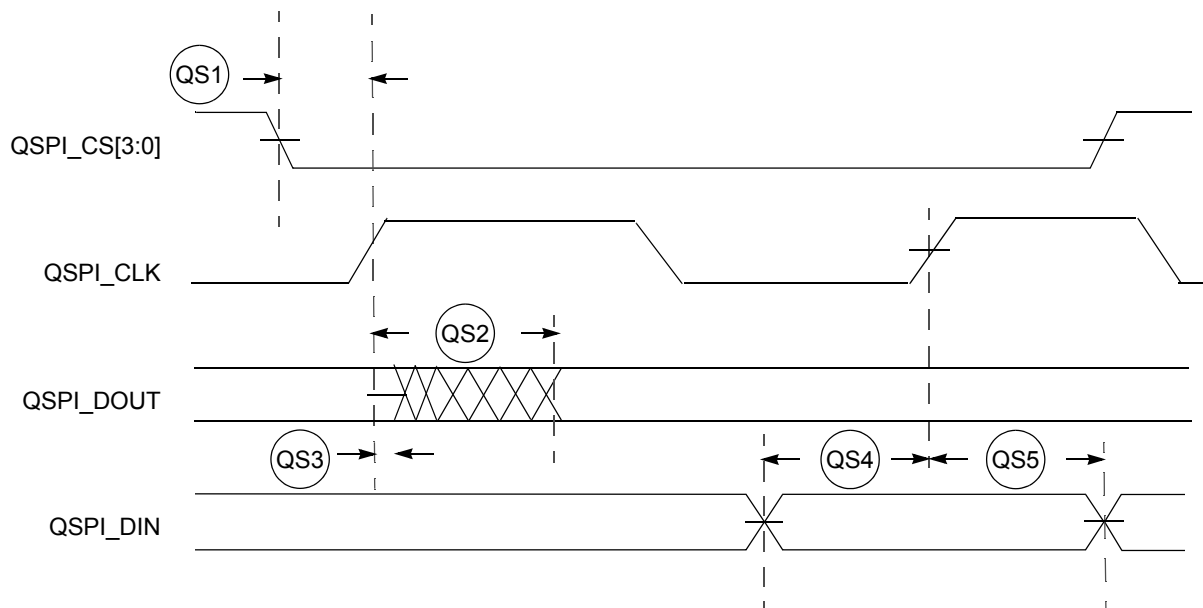

Figure 15. QSPI Timing

2.19 JTAG and Boundary Scan Timing

Table 28. JTAG and Boundary Scan Timing

| Num | Characteristics ¹ | Symbol | Min | Max | Unit |
|-----|--|--------------|--------------------|-----|-------------|
| J1 | TCLK frequency of operation | f_{JCYC} | DC | 1/4 | $f_{sys/2}$ |
| J2 | TCLK cycle period | t_{JCYC} | $4 \times t_{CYC}$ | — | ns |
| J3 | TCLK clock pulse width | t_{JCW} | 26 | — | ns |
| J4 | TCLK rise and fall times | t_{JCRF} | 0 | 3 | ns |
| J5 | Boundary scan input data setup time to TCLK rise | t_{BSDST} | 4 | — | ns |
| J6 | Boundary scan input data hold time after TCLK rise | t_{BSDHT} | 26 | — | ns |
| J7 | TCLK low to boundary scan output data valid | t_{BSDV} | 0 | 33 | ns |
| J8 | TCLK low to boundary scan output high Z | t_{BSDZ} | 0 | 33 | ns |
| J9 | TMS, TDI input data setup time to TCLK rise | t_{TAPBST} | 4 | — | ns |
| J10 | TMS, TDI Input data hold time after TCLK rise | t_{TAPBHT} | 10 | — | ns |
| J11 | TCLK low to TDO data valid | t_{TDODV} | 0 | 26 | ns |
| J12 | TCLK low to TDO high Z | t_{TDODZ} | 0 | 8 | ns |
| J13 | \overline{TRST} assert time | t_{TRSTAT} | 100 | — | ns |
| J14 | \overline{TRST} setup time (negation) to TCLK high | t_{TRSTST} | 10 | — | ns |

¹ JTAG_EN is expected to be a static signal. Hence, it is not associated with any timing.

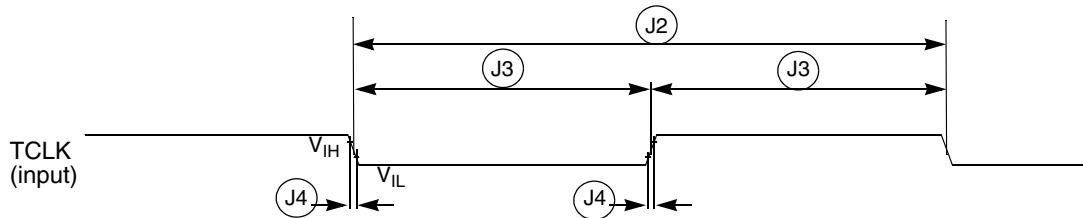

Figure 16. Test Clock Input Timing

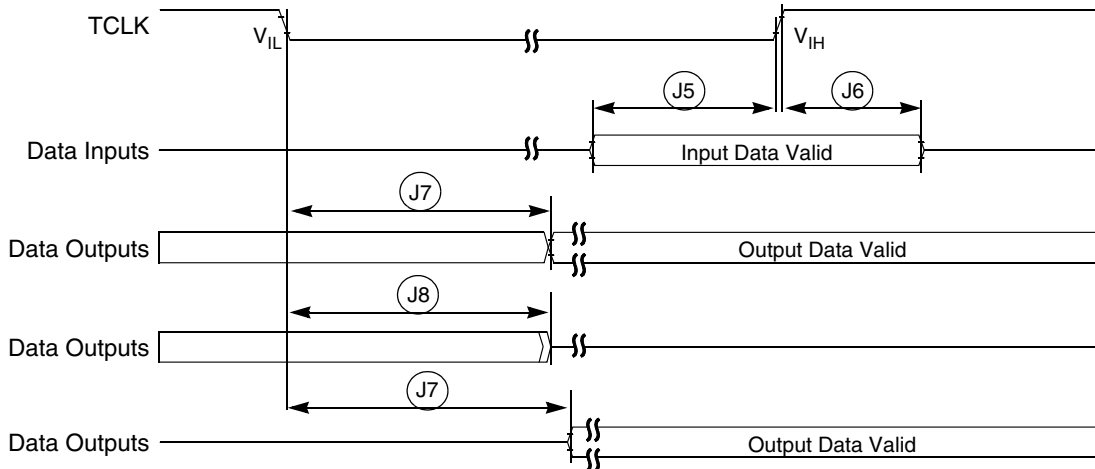

Figure 17. Boundary Scan (JTAG) Timing

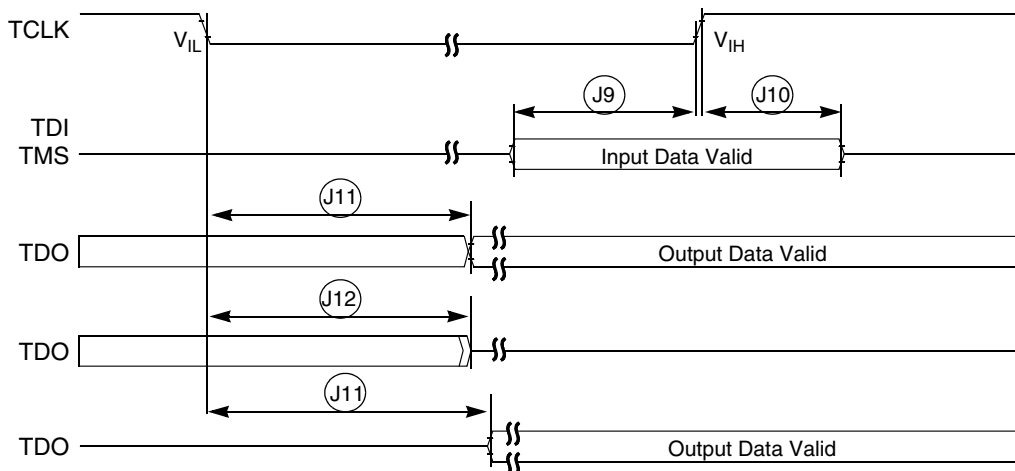

Figure 18. Test Access Port Timing

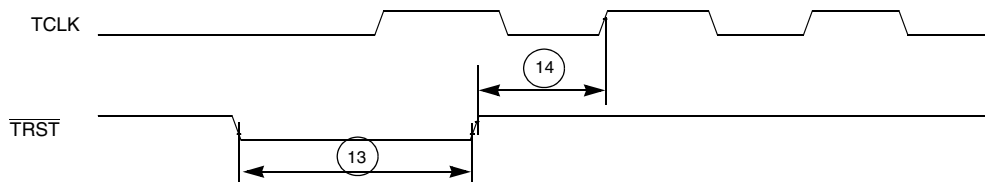

Figure 19. TRST Timing

2.20 Debug AC Timing Specifications

Table 29 lists specifications for the debug AC timing parameters shown in Figure 21.

Table 29. Debug AC Timing Specification

| Num | Characteristic | 66/80 MHz | | Units |
|-----------------|--|--------------------|------|-------|
| | | Min | Max | |
| D1 | PST, DDATA to CLKOUT setup | 4 | — | ns |
| D2 | CLKOUT to PST, DDATA hold | 1.5 | — | ns |
| D3 | DSI-to-DSCLK setup | $1 \times t_{CYC}$ | — | ns |
| D4 ¹ | DSCLK-to-DSO hold | $4 \times t_{CYC}$ | — | ns |
| D5 | DSCLK cycle time | $5 \times t_{CYC}$ | — | ns |
| D6 | \overline{BKPT} input data setup time to CLKOUT rise | 4 | — | ns |
| D7 | \overline{BKPT} input data hold time to CLKOUT rise | 1.5 | — | ns |
| D8 | CLKOUT high to \overline{BKPT} high Z | 0.0 | 10.0 | ns |

¹ DSCLK and DSI are synchronized internally. D4 is measured from the synchronized DSCLK input relative to the rising edge of CLKOUT.

Figure 20 shows real-time trace timing for the values in Table 29.

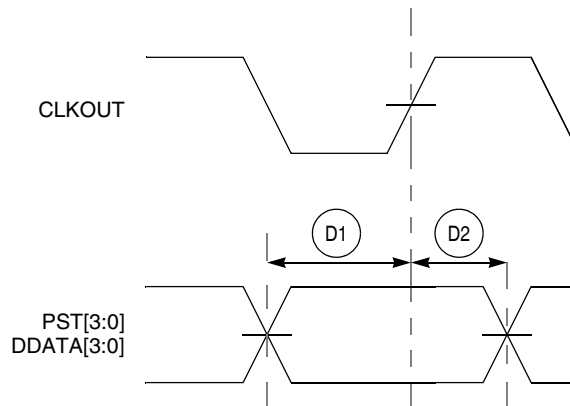

Figure 20. Real-Time Trace AC Timing

Figure 21 shows BDM serial port AC timing for the values in Table 29.

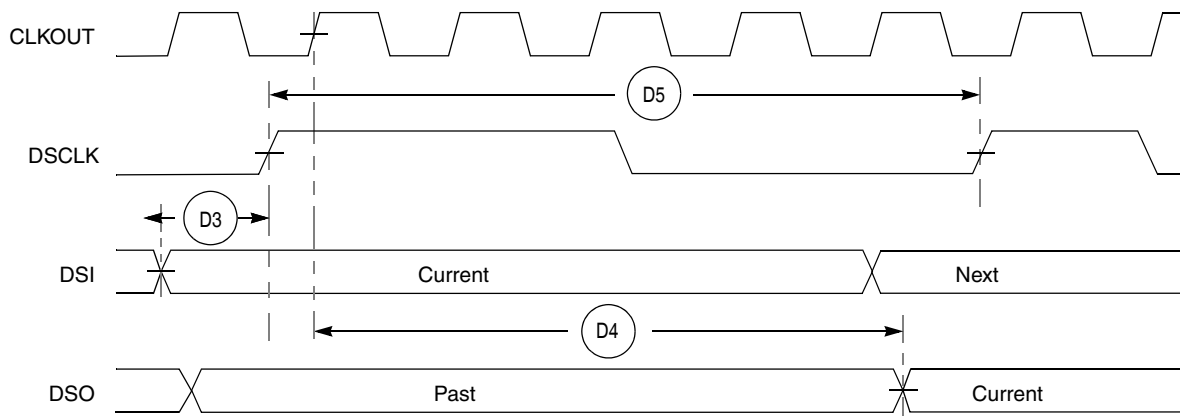

Figure 21. BDM Serial Port AC Timing

3 Package Information

The latest package outline drawings are available on the product summary pages on <http://www.freescale.com/coldfire>. Table 30 lists the case outline numbers per device. Use these numbers in the web page's keyword search engine to find the latest package outline drawings.

Table 30. Package Information

| Device | Package Type | Case Outline Numbers |
|----------|------------------------------|--------------------------------|
| MCF52252 | 100 LQFP | 98ASS23308W |
| MCF52254 | | |
| MCF52255 | | |
| MCF52256 | 144 LQFP or 144 MAPBGA | 98ASS23177W 98ASH70694A |
| MCF52258 | | |
| MCF52259 | | |

4 Revision History

Table 31. Revision History

| Revision | Description |
|----------|--|
| 0 | Initial public release. |
| 1 | <ul style="list-style-type: none"> Added package dimensions to package diagrams Added listing of devices for MCF52259 family Changed “Four-channel general-purpose timer (GPT) capable of input capture/output compare, pulse width modulation (PWM), and pulse accumulation” to “Four-channel general-purpose timer (GPT) capable of input capture/output compare, pulse width modulation (PWM), pulse-code modulation (PCM), and pulse accumulation” Updated the figure Pinout Top View (144 MAPBGA) Removed an extraneous instance of the table Pin Functions by Primary and Alternate Purpose In the table Pin Functions by Primary and Alternate Purpose, changed a footnote from “This list for power and ground does not include those dedicated power/ground pins included elsewhere, such as in the ADC” to “This list for power and ground does not include those dedicated power/ground pins included elsewhere, such as in the ADC, USB, and PLL” In the table SGFM Flash Program and Erase Characteristics, changed “(V_{DDF} = 2.7 to 3.6 V)” to “(V_{DD} = 3.0 to 3.6 V)” In the table SGFM Flash Module Life Characteristics, changed “(V_{DDF} = 2.7 to 3.6 V)” to “(V_{DD} = 3.0 to 3.6 V)” In the table Oscillator and PLL Specifications, changed “V_{DD} and V_{DDPLL} = 2.7 to 3.6 V” to “V_{DD} and V_{DDPLL} = 3.0 to 3.6 V” In the table Reset and Configuration Override Timing, changed “V_{DD} = 2.7 to 3.6 V” to “V_{DD} = 3.0 to 3.6 V” |
| 2 | <ul style="list-style-type: none"> Added EzPort Electrical Specifications. Updated Table 2 for part numbers. In Table 13, added slew rate column, updated derive strength, pull-up/pull-down values, JTAG pin alternate functions, removed Wired/OR control column, and reordered AN[7:0] list of pin numbers for 144 LQFP and 100 LQFP. Updated Table 14. Updated Table 13, to change MIN voltage spec for Standby Voltage (VSTBY) to 1.8V (from 3.0V). Updated Figure 2 for RTC_EXTAL and RTC_XTAL pin positions. |
| 3 | <ul style="list-style-type: none"> Updated EzPort Electrical Specifications Added hysteresis note in the DC electrical table Clarified pin function table for VSS pins. Clarified orderable part summary. |
| 4 | <ul style="list-style-type: none"> Updated EXTAL input high voltage (External reference) Maximum to “3.0V” (Instead of “VDD”). Also, added a footnote saying, “This value has been update” Updated crystal frequency value to 25 MHz |
| 5 | <ul style="list-style-type: none"> Updated TOC |

How to Reach Us:

Home Page:

www.freescale.com

Web Support:

<http://www.freescale.com/support>

USA/Europe or Locations Not Listed:

Freescale, Inc.

Technical Information Center, EL516
2100 East Elliot Road
Tempe, Arizona 85284
1-800-521-6274 or +1-480-768-2130
www.freescale.com/support

Europe, Middle East, and Africa:

Freescale Halbleiter Deutschland GmbH
Technical Information Center
Schatzbogen 7
81829 Muenchen, Germany
+44 1296 380 456 (English)
+46 8 52200080 (English)
+49 89 92103 559 (German)
+33 1 69 35 48 48 (French)
www.freescale.com/support

Japan:

Freescale Japan Ltd.
Headquarters
ARCO Tower 15F
1-8-1, Shimo-Meguro, Meguro-ku,
Tokyo 153-0064
Japan
0120 191014 or +81 3 5437 9125
support.japan@freescale.com

Asia/Pacific:

Freescale China Ltd.
Exchange Building 23F
No. 118 Jianguo Road
Chaoyang District
Beijing 100022
China
+86 10 5879 8000
support.asia@freescale.com

Freescale Literature Distribution Center
1-800-441-2447 or +1-303-675-2140
Fax: +1-303-675-2150
LDCForFreescaleSemiconductor@hibbertgroup.com

Information in this document is provided solely to enable system and software implementers to use Freescale products. There are no express or implied copyright licenses granted hereunder to design or fabricate any integrated circuits or integrated circuits based on the information in this document.

Freescale reserves the right to make changes without further notice to any products herein. Freescale makes no warranty, representation or guarantee regarding the suitability of its products for any particular purpose, nor does Freescale assume any liability arising out of the application or use of any product or circuit, and specifically disclaims any and all liability, including without limitation consequential or incidental damages. "Typical" parameters that may be provided in Freescale data sheets and/or specifications can and do vary in different applications and actual performance may vary over time. All operating parameters, including "Typicals", must be validated for each customer application by customer's technical experts. Freescale does not convey any license under its patent rights nor the rights of others. Freescale products are not designed, intended, or authorized for use as components in systems intended for surgical implant into the body, or other applications intended to support or sustain life, or for any other application in which the failure of the Freescale product could create a situation where personal injury or death may occur. Should Buyer purchase or use Freescale products for any such unintended or unauthorized application, Buyer shall indemnify and hold Freescale and its officers, employees, subsidiaries, affiliates, and distributors harmless against all claims, costs, damages, and expenses, and reasonable attorney fees arising out of, directly or indirectly, any claim of personal injury or death associated with such unintended or unauthorized use, even if such claim alleges that Freescale was negligent regarding the design or manufacture of the part.

RoHS-compliant and/or Pb-free versions of Freescale products have the functionality and electrical characteristics as their non-RoHS-compliant and/or non-Pb-free counterparts. For further information, see <http://www.freescale.com> or contact your Freescale sales representative.

For information on Freescale's Environmental Products program, go to <http://www.freescale.com/epp>.

Freescale™ and the Freescale logo are trademarks of Freescale, Inc. All other product or service names are the property of their respective owners.
© Freescale, Inc. 2011, 2012. All rights reserved.

Document Number: MCF52259

Rev. 5
5/2012



Mouser Electronics

Authorized Distributor

Click to View Pricing, Inventory, Delivery & Lifecycle Information:

[NXP:](#)

[MCF52256AG80](#) [MCF52256CAG66](#) [MCF52258CAG66](#) [MCF52264AF80](#) [MCF52258CVN66J](#) [MCF52258VN80J](#)
[MCF52259CVN80J](#) [MCF52259CAG80R](#)