

Contents

1	Description	6
2	Functional description	9
3	SMBus interface	10
3.1	SMBus protocol	10
3.2	WRITE byte	11
3.3	READ byte	11
3.4	SEND byte	11
3.5	RECEIVE byte	11
3.6	SMBus addresses	12
3.7	SMBus timeout	12
3.8	Alert response address	12
4	STTS751 register summary	13
4.1	STTS751 register formats and details	14
4.2	Temperature register format	14
4.3	Temperature limit register format	15
4.4	Temperature examples	15
4.5	Status register	16
4.6	Configuration register	17
4.7	Conversion rate register	18
4.8	One-shot register	19
4.9	Therm limit	20
4.10	Therm hysteresis	20
4.11	SMBus timeout register	20
4.12	STTS751 product ID	21
4.13	STTS751 manufacturer's ID	21
4.14	STTS751 revision ID	21
5	EVENT output	22

6	Addr/Therm output	23
7	Maximum ratings	24
8	DC and AC parameters	25
9	Package information	28
	9.1 UDFN-6L package information	29
	9.2 Packing information	31
10	Part numbering	33
11	Revision history	34

List of tables

Table 1.	Device summary	1
Table 2.	Signal names	6
Table 3.	Pin descriptions.	7
Table 4.	SMBus WRITE byte protocol	11
Table 5.	SMBus READ byte protocol	11
Table 6.	SMBus SEND byte protocol	11
Table 7.	SMBus RECEIVE byte protocol	11
Table 8.	SMBus protocol response to ARA	12
Table 9.	Registers/pointers	13
Table 10.	Pointer register format	14
Table 11.	Temperature register (two's complement)	14
Table 12.	Temperature limit register (two's complement format)	15
Table 13.	Temperature examples (two's complement format)	15
Table 14.	Status register.	16
Table 15.	Configuration register	17
Table 16.	Conversion resolution	18
Table 17.	Conversion rate register	18
Table 18.	Conversion rates.	19
Table 19.	One-shot register	19
Table 20.	Therm limit	20
Table 21.	Therm hysteresis	20
Table 22.	SMBus timeout register.	20
Table 23.	Product ID register	21
Table 24.	Manufacturer's ID register.	21
Table 25.	Revision ID register.	21
Table 26.	Absolute maximum ratings	24
Table 27.	Operating and AC measurement conditions.	25
Table 28.	DC and AC characteristics	26
Table 29.	AC characteristics	27
Table 30.	UDFN-6L (2 mm x 2 mm x 0.5 mm) package mechanical data	29
Table 31.	Carrier tape dimensions for UDFN-6L package	31
Table 32.	Reel dimensions for 8 mm carrier tape - UDFN-6L package	32
Table 33.	Ordering information scheme	33
Table 34.	Document revision history.	34

List of figures

Figure 1.	Logic diagram	6
Figure 2.	Pinout	7
Figure 3.	Block diagram	8
Figure 4.	Application hardware hookup	8
Figure 5.	SMBus timing diagram	10
Figure 6.	<u>EVENT</u> output	22
Figure 7.	Therm output	23
Figure 8.	AC measurement I/O waveform	25
Figure 9.	UDFN-6L (2 mm x 2 mm x 0.5 mm) package outline	29
Figure 10.	UDFN-6L package footprint	30
Figure 11.	Carrier tape for UDFN-6L package	31
Figure 12.	Reel schematic	32

1 Description

The STTS751 is a digital temperature sensor which communicates over a 2-wire SMBus 2.0 compatible bus. The temperature is measured with a user-configurable resolution between 9 and 12 bits. At 9 bits, the smallest step size is 0.5 °C, and at 12 bits, it is 0.0625 °C. At the default resolution (10 bits, 0.25 °C/LSB), the conversion time is nominally 21 milliseconds.

The open-drain $\overline{\text{EVENT}}$ output is used to indicate an alarm condition in which the measured temperature has exceeded the user-programmed high limit or fallen below the low limit. When the $\overline{\text{EVENT}}$ pin is asserted, the host can respond using the SMBus Alert Response Address (ARA) protocol to which the STTS751 will respond by sending its slave address.

The STTS751 is a 6-pin device that supports user-configurable slave addresses. Via the pull-up resistor on the Addr/Therm pin, one of four different slave addresses can be specified. Two order numbers (STTS751-0 and STTS751-1) provide two different sets of slave addresses bringing the total available to eight. Thus, up to eight devices can share the same 2-wire SMBus without ambiguity, thereby allowing monitoring of multiple temperature zones in an application.

The two-wire interface can support transfer rates up to 400 kHz.

Figure 1. Logic diagram

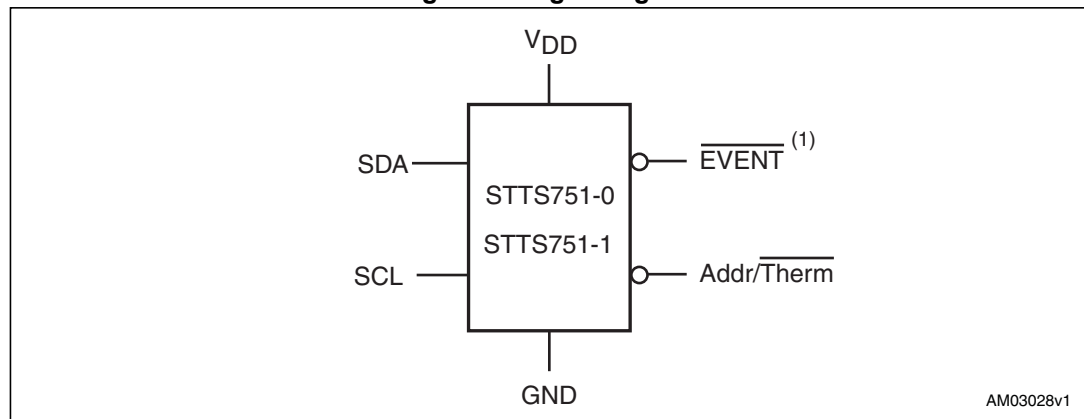

1. This pin may not float.

Table 2. Signal names

Symbol	Type	Description
Addr/Therm	Output	Address selection pin / thermal status pin
$\overline{\text{EVENT}}$	Output	Event (alert) output
SDA	I/O	SMBus interface data I/O
SCL	Input	SMBus interface clock input
V _{DD}	Power	Device power supply
GND	Ground	Device ground

Figure 2. Pinout

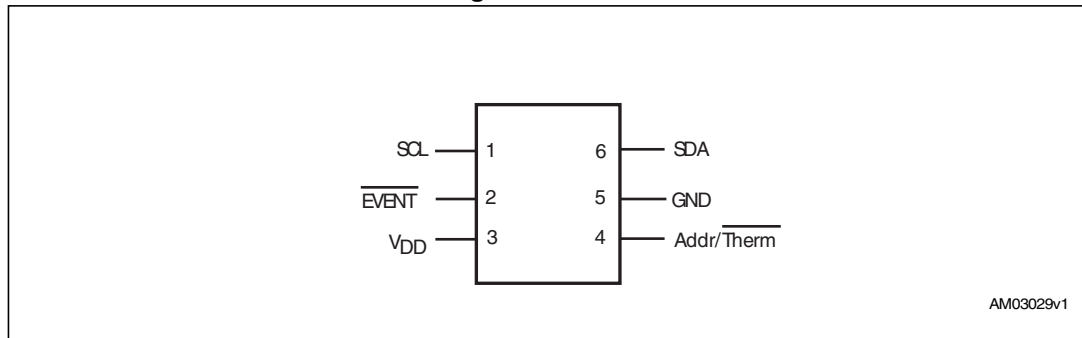
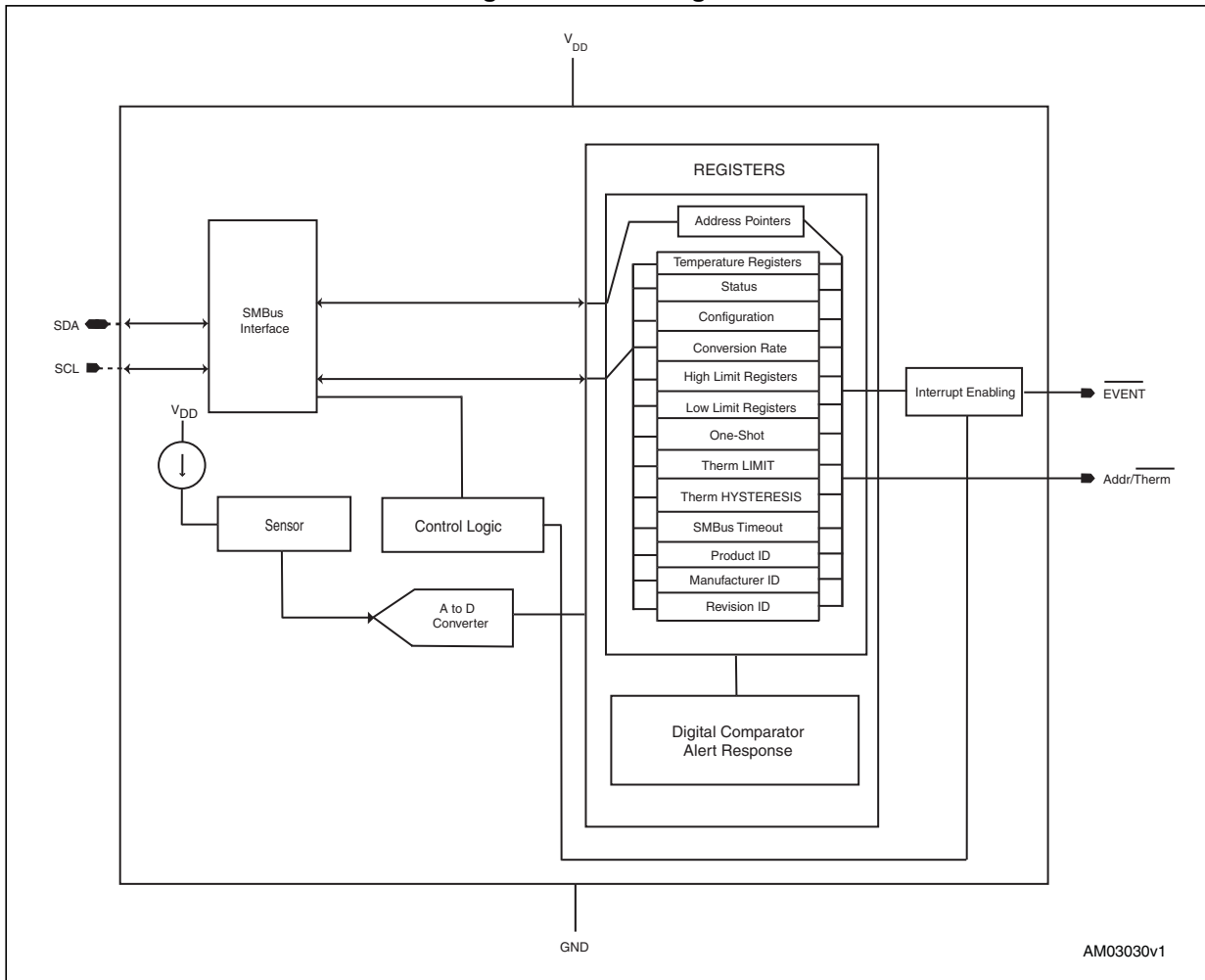

Table 3. Pin descriptions

Pin	Name	Description
1	SCL	SMBus clock
2	$\overline{\text{EVENT}}$	Open-drain interrupt output. Output supports the SMBus Alert (ARA). Note: This pin may not float.
3	V_{DD}	Power supply V_{DD}
4	$\overline{\text{Addr/Therm}}$	Open-drain output that can be used to turn on/off a fan or throttle a CPU clock in the event of an overtemperature condition. The pin at power-up determines the SMBus slave address according to the pull-up resistor value as shown in Table 1 . This pin must have a pull-up resistor connected to the same voltage as V_{DD} or tied to GND (pin cannot float). Total capacitance on this pin must be <100 pF. Note: By tying $\overline{\text{Addr/Therm}}$ to ground, the device functions as one address device only. The $\overline{\text{Therm}}$ functionality is then not available. The address for device STTS751-0 is 72h and the address for device STTS751-1 is 76h.
5	GND	GND
6	SDA	SMBus data input/output

Figure 3. Block diagram



AM03030v1

Figure 4. Application hardware hookup

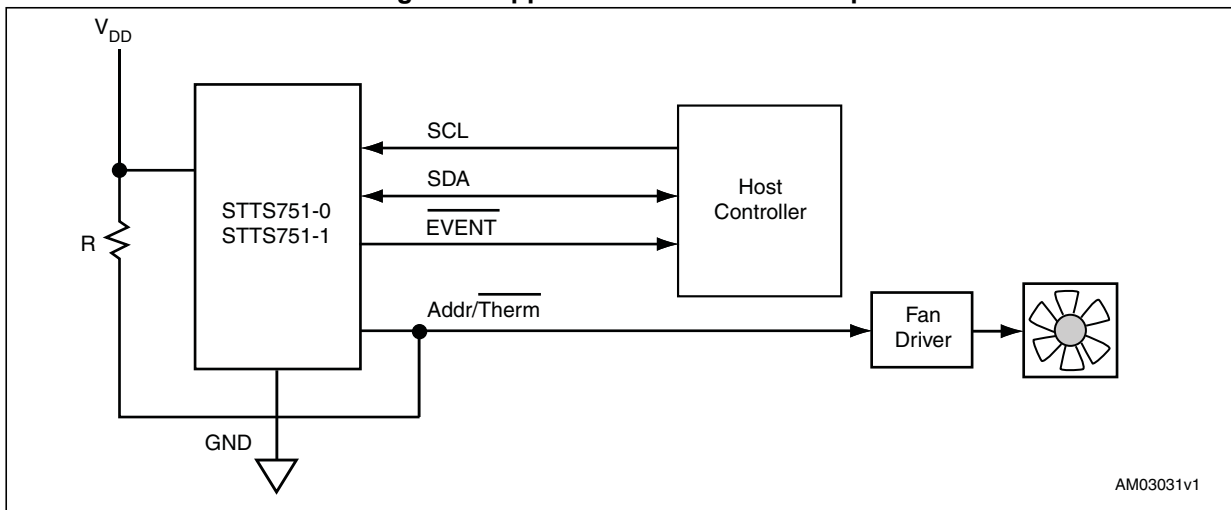

AM03031v1

2 Functional description

The STTS751 digital temperature sensor acquires the temperature and stores it in the temperature register. The resolution is programmable which allows the host controller to select the optimal configuration between sensitivity and conversion times. The STTS751 can be placed in standby mode to minimize power consumption.

The user can control the update rate of the temperature measurements via the configuration register ([Table 15 on page 17](#)). Sample rates can be adjusted from once every 16 seconds up to 32 samples per second, in powers-of-2 steps.

These devices also offer a one-shot feature. When the device is in the standby mode, writing to the one-shot register initiates a single temperature conversion. The result is compared with the limit registers, and the outputs updated accordingly. Then the device returns to the standby mode. Operating the device in this mode allows for very low average power consumption, thereby making this device ideal for low power applications.

The device supports the SMBus Alert Response address (ARA) protocol. The ARA is polled by the controller (host) device that supports this protocol whenever it detects that the $\overline{\text{EVENT}}$ pin has been asserted. The STTS751 will respond with its device address (refer to [Section 3.8 on page 12](#)).

The STTS751 contains 16 registers. The register summary is shown in [Table 9 on page 13](#). Using register addresses not specified in the table may result in an incorrect response. These registers and their functions are described in more detail in the following sections.

3 SMBus interface

3.1 SMBus protocol

The STTS751 communicates over a 2-wire serial interface compatible with the SMBus standard. Temperature data, alarm limits and configuration information are communicated over the bus. A detailed timing diagram is shown below in [Figure 5](#).

Figure 5. SMBus timing diagram

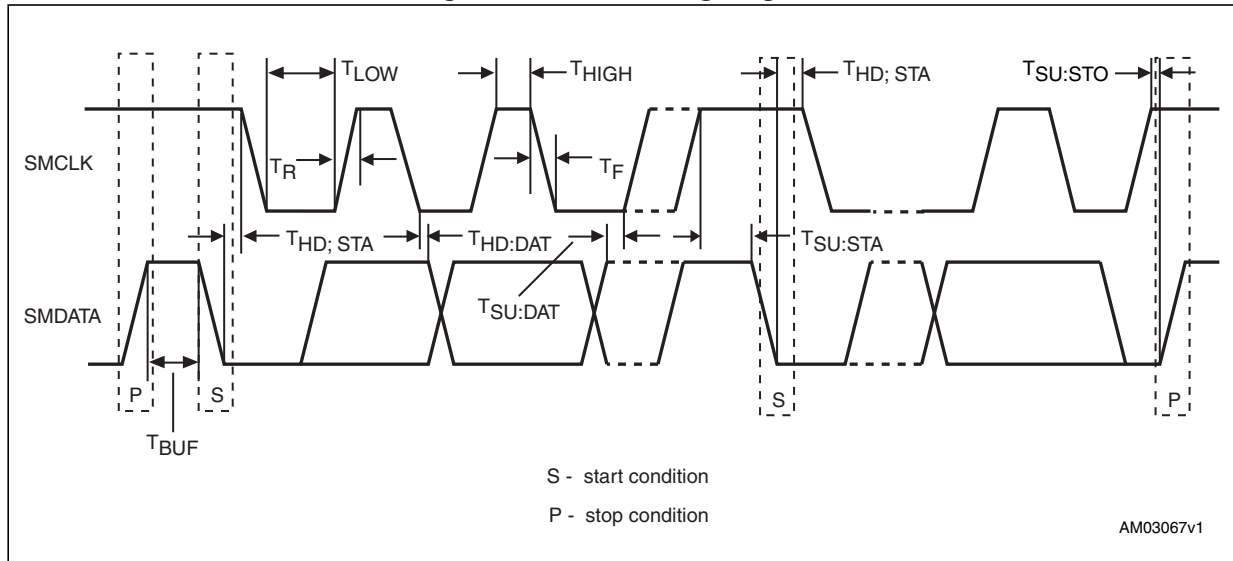

The STTS751 supports standard SMBus protocols (see [Table 4](#), [5](#), [6](#), and [7](#)).

- WRITE byte
- READ byte
- SEND byte
- RECEIVE byte
- Alert response address

3.2 WRITE byte

The WRITE byte protocol is used to write one byte of data to the registers as shown in [Table 4](#). The gray data is sent by the STTS751 while the white data is sent by the host.

Table 4. SMBus WRITE byte protocol

Start	Slave address	WR	ACK	Register address	ACK	Data	ACK	Stop
1 bit	7 bits	1 bit	1 bit	8 bits	1 bit	8 bits	1 bit	1 bit

3.3 READ byte

The READ byte protocol is used to read one byte of data from the registers as shown in [Table 5](#).

Table 5. SMBus READ byte protocol

Start	Slave address	WR	ACK	Register address	ACK	Start	Slave address	RD	ACK	Data	NACK	Stop
1 bit	7 bits	1 bit	1 bit	8 bits	1 bit	1 bit	7 bits	1 bit	1 bit	8 bits	1 bit	1 bit

3.4 SEND byte

The SEND byte protocol is used to set the internal address register to the correct address. It sends a register address with no data (see [Table 6](#)). The SEND byte can be followed by the RECEIVE byte protocol described below in order to read data from the register.

Table 6. SMBus SEND byte protocol

Start	Slave address	WR	ACK	Register address	ACK	Stop
1 bit	7 bits	1 bit	1 bit	8 bits	1 bit	1 bit

3.5 RECEIVE byte

The RECEIVE byte protocol is used to read data from the register when the internal register address pointer is known (see [Table 7](#)). This can be used for consecutive reads of the same register.

Table 7. SMBus RECEIVE byte protocol

Start	Slave address	RD	ACK	Data	NACK	Stop
1 bit	7 bits	1 bit	1 bit	8 bits	1 bit	1 bit

3.6 SMBus addresses

The STTS751 is available in two versions. Each version has 4 slave addresses determined by the pull-up resistor value connected to the Addr/Therm pin. Refer to [Table 1](#) for valid address and recommended resistor values. The device will not respond to an invalid slave address.

3.7 SMBus timeout

The STTS751 supports SMBus timeout which is enabled by default at power-up. This can be disabled via bit 7 in the timeout register, refer to [Section 4.11: SMBus timeout register](#). When timeout is enabled, the STTS751 will time out after 25 to 35 ms of inactivity.

The STTS751 supports the SMBus timeout feature. If the host holds SCL low or the device drives SDA low for more than $t_{TIMEOUT}$ (max), the STTS751 resets and releases the bus. This feature is turned on by default. The STTS751 also supports timeout while in standby mode and when the device is driving SDA low.

Note: The STTS751 never drives the clock line and it does not support clock stretching.

3.8 Alert response address

The STTS751 supports the SMBus alert response address (ARA) protocol. In the event of an out-of-limit temperature measurement, the \overline{EVENT} output will be asserted. In response, the host (supporting the ARA protocol) will send the SMBus Alert Response Address to the general (slave) address of 0001_100b. All devices with active interrupts will respond with their client addresses as shown in [Table 1 on page 1](#) (with the LSB bit set to 0).

The STTS751 will acknowledge the ARA and respond with its slave device address. [Table 8](#) shows the ARA transfer. See [Section 5](#) for more information.

Table 8. SMBus protocol response to ARA

Field	START	ALERT RESPONSE ADDRESS	RD	ACK	STTS751 SLAVE ADDRESS	NACK	STOP
Bits	1	7	1	1	8	1	1

4 STTS751 register summary

The STTS751 uses 8-bit registers. Variables longer than 8 bits are managed in byte pairs. For example, when reading a 10-bit temperature value (10 bits is the default resolution.) the application must read two registers and then concatenate the upper byte with the 2 most significant bits of the lower byte.

Table 9 below summarizes the register map for the device. Accessing any invalid address results in indeterminate data.

Table 9. Registers/pointers

Address pointers (h)	STTS751 register map			Power-up default values binary (dec)
	Device registers name	Size	Type	
00	Temperature value high byte	8	R	undefined
01	Status	8	R	undefined
02	Temperature value low byte	8	R	undefined
03	Configuration	8	R/W	0000 0000
04	Conversion rate	8	R/W	0000 0100
05	Temperature high limit high byte	8	R/W	0101 0101 (85 °C)
06	Temperature high limit low byte	8	R/W	0000 0000
07	Temperature low limit high byte	8	R/W	0000 0000 (0 °C)
08	Temperature low limit low byte	8	R/W	0000 0000
0F	One-shot	8	W	N/A
20	THERM limit	8	R/W	0101 0101 (85 °C)
21	THERM hysteresis	8	R/W	0000 1010 (10 °C)
22	SMBus timeout enable	8	R/W	1000 0000 (Enabled)
FD	Product ID register	8	R	STTS751-0 [0000 0000] STTS751-1 [0000 0001]
FE	Manufacturer ID	8	R	0101 0011 (53h)
FF	Revision number	8	R	0000 0001

In the following sections are the detailed descriptions of the registers along with their power-up default values. Examples are also included.

4.1 STTS751 register formats and details

The STTS751 register set is comprised of the 16 addresses shown in [Table 9](#). The individual registers are accessed by transferring their addresses via the SMBus interface as shown in [Section 3.2](#), [3.3](#), and [3.4](#). In the case of the RECEIVE byte sequence ([Section 3.5](#)) the address used is the address sent in the previous WRITE, READ or SEND byte sequence.

An example read sequence of the Therm hysteresis register, address 21h, with its default value, 0Ah, is shown below. The slave address used is 90h. The gray data is sent by the STTS751 while the white data is sent by the host.

Table 10. Pointer register format

START	SLAVE ADDRESS	WR	ACK	REGISTER ADDRESS	ACK	START	SLAVE ADDRESS	RD	ACK	DATA	NACK	STOP
	1001_000	0		0010_0001			1001_000	1		0000_1010		

Note: All eight bits are used to select the register.

4.2 Temperature register format

The temperature data is a 12-bit number and is stored in two's complement format spanning the high byte and low byte registers as shown in [Table 11](#).

Table 11. Temperature register (two's complement)

ADDR (hex)	R/W	Register	b7	b6	b5	b4	b3	b2	b1	b0	Power-up default (hex)
00	R	Temperature - high byte	sign	64 °C	32 °C	16 °C	8 °C	4°C	2 °C	1 °C	00
02	R	Temperature - low byte	½ °C	¼ °C	1/8 °C	1/16 °C	0	0	0	0	00

The integer portion of the temperature is stored in the high byte, and the fractional portion in the low byte. The lower four bits of the low byte will always read 0. At power-up, the STTS751 defaults to 10-bit resolution. Thus, bits b5 and b4 of the lower byte will also read 0 until the device is configured to a higher resolution (via the Tres bits in the configuration register).



4.3 Temperature limit register format

The high and low limit registers have the same format as the temperature register with the integer portion of the two's complement value stored in the high byte and the fractional portion in the low byte. These registers are read-write.

Note that the high limit defaults to 85 °C.

Table 12. Temperature limit register (two's complement format)

ADDR (hex)	R/W	Register	b7	b6	b5	b4	b3	b2	b1	b0	Power-up default (hex)
05	R/W	High limit - high byte	sign	64 °C	32 °C	16 °C	8 °C	4°C	2 °C	1 °C	55 (85 °C, dec)
06	R/W	High limit - low byte	½ °C	¼ °C	1/8 °C	1/16 °C	0	0	0	0	00
07	R/W	Low limit - high byte	sign	64 °C	32 °C	16 °C	8 °C	4°C	2 °C	1 °C	00
08	R/W	Low limit - low byte	½ °C	¼ °C	1/8 °C	1/16 °C	0	0	0	0	00

4.4 Temperature examples

The table below shows several examples of how the data is arranged in the high and low byte pairs used for the temperature and limit registers.

Table 13. Temperature examples (two's complement format)

		b7	b6	b5	b4	b3	b2	b1	b0
Weighting of the bits	High byte	sign	64 °C	32 °C	16 °C	8 °C	4°C	2 °C	1 °C
	Low byte	½ °C	¼ °C	1/8 °C	1/16 °C	0	0	0	0
-64 °C	High byte	1	1	0	0	0	0	0	0
	Low byte	0	0	0	0	0	0	0	0
-63 °C	High byte	1	1	0	0	0	0	0	1
	Low byte	0	0	0	0	0	0	0	0
-1 °C	High byte	1	1	1	1	1	1	1	1
	Low byte	0	0	0	0	0	0	0	0
+1 °C	High byte	0	0	0	0	0	0	0	1
	Low byte	0	0	0	0	0	0	0	0
+5.3125 °C ⁽¹⁾	High byte	0	0	0	0	0	1	0	1
	Low byte	0	1	0	1	0	0	0	0
+125 °C	High byte	0	1	1	1	1	1	0	1
	Low byte	0	0	0	0	0	0	0	0

1. With 12-bit resolution selected.

Note: The maximum and minimum values for the temperature registers are 127.9375 (7F:F0h, high byte : low byte) and -64 (C0:00h), respectively. This also applies to the high and low limit registers.



4.5 Status register

Table 14. Status register

ADDR (hex)	R/W	Register	b7	b6	b5	b4	b3	b2	b1	b0	Power-up default (hex)
01	R	Status	Busy	T _{HIGH}	T _{LOW}	RFU	RFU	RFU	RFU	THRM	undefined

The STTS751 status register is read-only and located at address 01h. The various status bits function as described below.

Busy: [7] Bit = 1 when a temperature conversion is in progress.

T_{HIGH}: [6] Bit = 1 indicates temperature high limit has been exceeded ($T_A > \text{high limit}$). T_{HIGH} is cleared when the status register is read, provided the condition no longer exists.

T_{LOW}: [5] Bit = 1 indicates the is at or below the low limit ($T_A \leq \text{low limit}$). T_{LOW} is cleared when the status register is read, provided the condition no longer exists.

RFU: [4:1] Not used - reserved.

THRM: [0] Bit = 1 indicates the measured temperature has crossed the Therm limit. The THRM bit will go low when the temperature falls below the Therm limit minus the Therm Hysteresis. When the THRM bit is high, the $\text{Addr}/\overline{\text{Therm}}$ output will be asserted low.

4.6 Configuration register

The STTS751 configuration register is read/write and controls the functionality of temperature measurements. It is located at address 03h. The configuration register bits function as described below.

Table 15. Configuration register

ADDR (hex)	R/W	Register	b7	b6	b5	b4	b3	b2	b1	b0	Power-up default (hex)
03	R/W	Configuration	MASK1	$\overline{\text{RUN/STOP}}$	0	RFU	Tres1	Tres0	RFU	RFU	00

Description

MASK1: [bit 7]

- 0: $\overline{\text{EVENT}}$ is enabled. Any out-of-limit condition asserts the EVENT pin (active low).
- 1: $\overline{\text{EVENT}}$ is disabled.

$\overline{\text{RUN/STOP}}$: [bit 6]

- 0: Device is running in continuous conversion mode.
- 1: Device is in standby mode drawing minimum power.

The $\overline{\text{RUN/STOP}}$ bit controls temperature conversions by the ADC. When this bit is 0, the ADC converts temperatures in continuous mode, at a rate as selected by the Conversion Rate register ([Section 4.7](#)). When the $\overline{\text{RUN/STOP}}$ bit is 1, the ADC will be in standby mode, thus reducing current supply significantly.

Note: The device can still be accessed via the SMBus while in standby mode.

When $\overline{\text{RUN/STOP}}$ is 1 and the one-shot register is written to, the ADC will execute a temperature measurement and then return to standby mode.

[bit 5]: This bit must always be 0.

RFU: [bit 4] Not used - reserved.

Tres1:Tres0 [bits 3 and 2]

These bits select one of the four programmable resolutions for temperature data on the STTS751 providing resolutions down to 0.0625 °C/LSB. The default resolution is 10 bits, 0.25 °C/LSB.

Table 16. Conversion resolution

Tres1:Tres0	Temperature resolution	LSB step size (°C)
00	10 bits (default)	0.25
01	11 bits	0.125
11	12 bits	0.0625
10	9 bits	0.5

RFU [bits 1 and 0] Not used - reserved.

4.7 Conversion rate register

The STTS751 conversion rate register is read/write and controls the number of times the temperature value will be updated each second.

Table 17. Conversion rate register

ADDR (hex)	R/W	Register	b7	b6	b5	b4	b3	b2	b1	b0	Power-up default (hex)
04	R/W	Conversion rate	0	0	0	0	CONV[3:0]			04 (1/sec)	

The upper four bits of the register are reserved and default to 0 on power-up. The lower four bits control the conversion rate as shown in the table below. The power-up default is 1 conversion per second. The current draw is proportional to the conversion rate, and goes up at higher rates.

Table 18. Conversion rates

CONV[3:0] (hex)	Conversions per second	Typical current (µA)	Comment
0	0.0625	15	
1	0.125		
2	0.25		
3	0.5		
4	1	20	
5	2		
6	4		
7	8	50	
8	16		9, 10, or 11-bit resolutions only
9	32	125	9 or 10-bit resolutions only
A-F	reserved		

Note: The user must program the conversion rate and resolution bits (Tres1:Tres0 in the configuration register, address 03h) to be consistent with this table. For a sampling rate of 32 conversions per second, the maximum resolution is 10 bits. For 16 conversions per second, the maximum is 11 bits.

4.8 One-shot register

The STTS751 can be configured to perform a single temperature conversion on demand. When the device is placed in standby mode (by setting $\overline{RUN/STOP}$ to 1 in the configuration register) a write to the one-shot register will invoke a temperature conversion. The device will set the busy bit while the conversion is in progress. The conversion is complete when the busy bit is cleared. The STTS751 returns to standby mode upon completion of the conversion.

The one-shot register is write-only and is located at address 0Fh. The value written to invoke the one-shot conversion is a don't care. The device responds only to the write at address 0Fh and ignores the value written.

Note: Writes to the one-shot register will be ignored when the STTS751 is in continuous conversion mode (ie. when $\overline{RUN/STOP}=0$).

Table 19. One-shot register

ADDR (hex)	R/W	Register	b7	b6	b5	b4	b3	b2	b1	b0	Power-up default (hex)
0F	W	One shot	X	X	X	X	X	X	X	X	n/a

4.9 Therm limit

The Therm limit is a read/write register located at address 20h. The power-on default value is 85 °C (55h). The format is 8-bit, two's complement integer. This is the same format as the upper byte of the temperature register (*Section 4.2: Temperature register format*).

Whenever the temperature exceeds the value of the therm limit, the Addr/Therm output will be asserted (low). See *Section 6* for more information.

Table 20. Therm limit

ADDR (hex)	R/W	Register	b7	b6	b5	b4	b3	b2	b1	b0	Power-up default (hex)
20	R/W	Therm	sign	64 °C	32 °C	16 °C	8 °C	4 °C	2 °C	1 °C	55 (85 °C, dec)

4.10 Therm hysteresis

The Therm hysteresis values controls the hysteresis for Addr/Therm output. Once Therm output has asserted, it will not de-assert until the temperature has fallen below the respective therm limit minus the therm hysteresis value. See *Section 5* for more information.

The therm hysteresis register is read/write and is located at address 21h. The power-up default value is 10 °C (0Ah). The format is 8-bit, two's complement integer.

Table 21. Therm hysteresis

ADDR (hex)	R/W	Register	b7	b6	b5	b4	b3	b2	b1	b0	Power-up default (hex)
21	R/W	Therm hysteresis	sign	64 °C	32 °C	16 °C	8 °C	4 °C	2 °C	1 °C	0A (10 °C, dec)

4.11 SMBus timeout register

At power-up, the STTS751 is configured with an SMBus timeout of 25 to 35 milliseconds (t_{TIMEOUT}). See *Section 3.7* for more information.

Table 22. SMBus timeout register

ADDR (hex)	R/W	Register	b7	b6	b5	b4	b3	b2	b1	b0	Power-up default (hex)
22	R/W	SMBus timeout	TIMEOUT	0	0	0	0	0	0	0	80

TIMEOUT: [bit 7]

1: SMBus timeout is enabled. Default condition.

0: SMBus timeout is disabled.

[bits 6:0] Not used - reserved.

4.12 STTS751 product ID

The two versions of the STTS751 as shown in [Table 1](#) can be identified via the read-only Product ID register at address FDh. The STTS751-0 has a Product ID of 00h. The STTS751-1 has a Product ID of 01h.

Table 23. Product ID register

ADDR (hex)	R/W	Register	b7	b6	b5	b4	b3	b2	b1	b0	hex
FD	R	Product ID	0	0	0	0	0	0	0	0	00: STTS751-0
			0	0	0	0	0	0	0	1	01: STTS751-1

4.13 STTS751 manufacturer's ID

The read-only manufacturer's ID is located at address FEh. For the STTS751, the value is 53h.

Table 24. Manufacturer's ID register

ADDR (hex)	R/W	Register	b7	b6	b5	b4	b3	b2	b1	b0	hex
FE	R	Mfg ID	0	1	0	1	0	0	1	1	53

4.14 STTS751 revision ID

The STTS751 revision ID register pointer is read-only and can be accessed at address FFh. The value is formatted as an unsigned, 8-bit integer.

Table 25. Revision ID register

ADDR (hex)	R/W	Register	b7	b6	b5	b4	b3	b2	b1	b0
FF	R	Revision ID	0	0	0	0	0	0	0	1

5 $\overline{\text{EVENT}}$ output

The STTS751 $\overline{\text{EVENT}}$ output is open drain and requires a pull-up resistor.

The $\overline{\text{EVENT}}$ pin is asserted (low) whenever the temperature exceeds the high limit or is equal to or below the low limit. Once asserted, the output will remain asserted until the STTS751 receives an SMBus Alert Response Address (ARA) from the host and acknowledges with its slave address. The output will be deasserted when the ARA is acknowledged. If the triggering condition is still true, the output will be reasserted at the next temperature conversion.

Figure 6 below shows how the $\overline{\text{EVENT}}$ output functions.

Figure 6. $\overline{\text{EVENT}}$ output

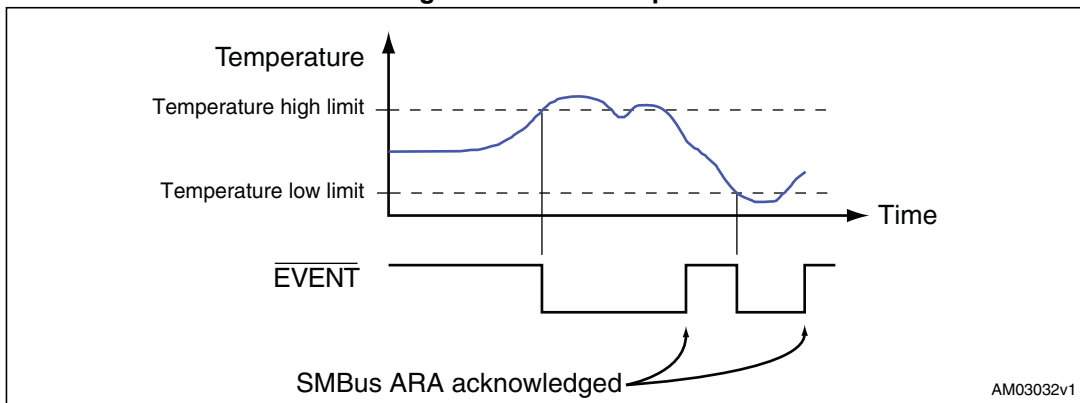

6 Addr/Therm output

The Addr/Therm pin functions normally as an output to alert the system of an over temperature condition. It is open drain and requires a pull-up resistor. During power-up, the pull-up value is sensed by the STTS751 to determine what its slave address will be as depicted in [Table 1](#).

The $\overline{\text{Therm}}$ output is asserted low whenever the temperature exceeds the Therm limit (address 20h). Only the upper 8 bits of the temperature register are used in the comparison with the Therm limit. Once asserted, $\overline{\text{Therm}}$ will remain asserted until temperature falls below the Therm limit minus the therm hysteresis value. For example, if the Therm limit is 25 °C, and the therm hysteresis value is 10 °C, the $\overline{\text{Therm}}$ output will assert when the temperature exceeds 25 °C. It will remain asserted until the temperature falls down to or below 15 °C (25 – 10).

This pin can be used to control a fan or other failsafe device as shown in [Figure 4 on page 8](#).

[Figure 7](#) below shows how the $\overline{\text{Therm}}$ output functions.

Figure 7. $\overline{\text{Therm}}$ output

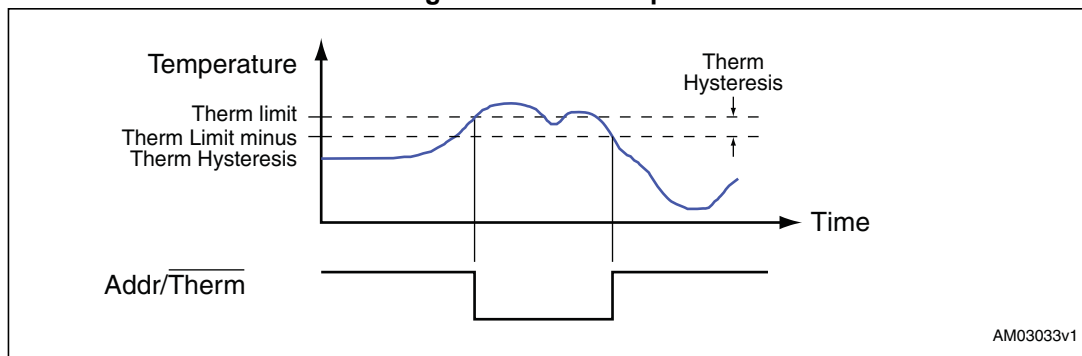

AM03033v1

7 Maximum ratings

Stressing the device above the rating listed in the absolute maximum ratings table may cause permanent damage to the device. These are stress ratings only and operation of the device at these or any other conditions above those indicated in the operating sections of this specification is not implied. Exposure to absolute maximum rating conditions for extended periods may affect device reliability.

Table 26. Absolute maximum ratings

Symbol	Parameter		Value	Unit
T_{STG}	Storage temperature (V_{DD} off)		-55 to 150	°C
$T_{SLD}^{(1)}$	Lead solder temperature		260	°C
V_{IO}	Input or output voltage		-0.3 to $V_{DD} + 0.3$	V
V_{DD}	Supply voltage		5.0	V
I_O	Output current		20	mA
θ_{JA}	Thermal resistance (junction to ambient)	UDFN-6L	78	°C/W

1. Reflow at peak temperature of 260 °C. The time above 255 °C must not exceed 30 seconds.

8 DC and AC parameters

This section summarizes the operating measurement conditions, and the DC and AC characteristics of the device. The parameters in the DC and AC characteristics tables that follow, are derived from tests performed under the measurement conditions summarized in [Table 27: Operating and AC measurement conditions](#). Designers should check that the operating conditions in their circuit match the operating conditions when relying on the quoted parameters.

Table 27. Operating and AC measurement conditions

Parameter	Conditions	Unit
V _{DD} supply voltage - temperature sensor	2.25 to 3.6	V
Ambient operating temperature (T _A)	-40 to +125	°C
Input rise and fall times	5	ns
Input pulse voltages	0.2 V _{DD} to 0.8 V _{DD}	V
Input and output timing reference voltages	0.3 V _{DD} to 0.7 V _{DD}	V

Figure 8. AC measurement I/O waveform

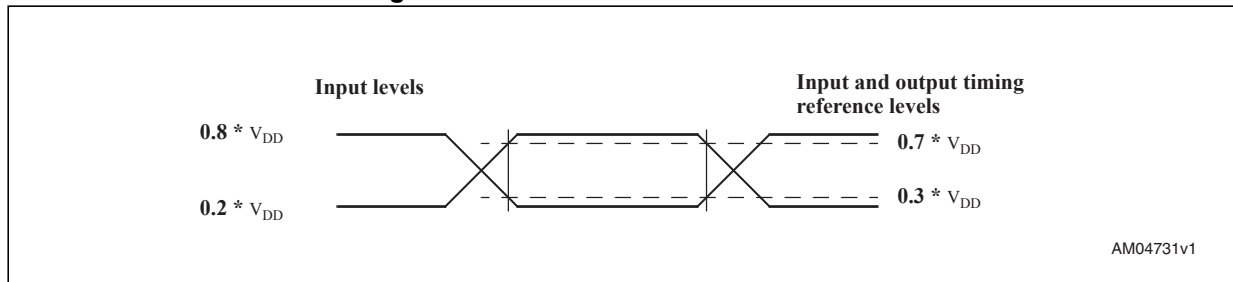

Table 28. DC and AC characteristics

Symbol	Description	Test condition ⁽¹⁾	Min	Typ ⁽²⁾	Max	Unit
V _{DD}	Supply voltage		2.25		3.6	V
I _{DD}	Operating current dependent upon conversion rate	0.0625 conversions/second ⁽³⁾		15	35	μA
		1 conversion/second ⁽³⁾		20	40	μA
		8 conversions/second		50	85	μA
		32 conversions/second		125	250	μA
I _{SB}	Standby current			3	8	μA
Temperature measurement						
Accuracy ⁽⁴⁾	2.25 V to 3.6 V	0 °C to 85 °C		±0.5	±1.5	°C
		-40 °C to +125 °C		±0.5	±2.5	°C
Resolution	STTS751 is programmable from 9 bits to 12 bits (0.5 °C/LSB to 0.0625 °C)	9-bit temperature data		0.5		°C/LSB
				9		bits
		10-bit temperature data (default)		0.25		°C/LSB
				10		bits
11-bit temperature data		0.125		°C/LSB		
		11		bits		
12-bit temperature data		0.0625		°C/LSB		
		12		bits		
t _{CONV}	Conversion time	9-bit		10.5	14	ms
		10-bit (default)		21	28	ms
		11-bit		42	56	ms
		12-bit		84	112	ms
V _{OL}	Low level output voltage Addr/Therm, EVENT	I _{OL} = 4 mA			0.4	V
I _{OH}	High level output leakage current EVENT, SDA, Addr/Therm	V _{OH} = V _{DD}			1	μA
SMBus interface inputs (SDA, SCL)						
V _{IH}	Input logic high (SCL, SDA)	2.3 V ≤ V _{DD} ≤ 3.6 V	0.7 x V _{DD}			V
V _{IL}	Input logic low (SCL, SDA)	2.3 V ≤ V _{DD} ≤ 3.6 V			0.3 x V _{DD}	V
I _{HI}	Logical "1" input current	0 V ≤ V _{IN} ≤ V _{DD}	-1		1	μA
I _{LI}	Logical "0" input current	0 V ≤ V _{IN} ≤ V _{DD}	-1		1	μA
C _{IN}	Input capacitance (SDA)			5		pF
I _{SINK}	SMBus output low sink current	SDA forced to 0.6 V	6			mA

Table 28. DC and AC characteristics (continued)

Symbol	Description	Test condition ⁽¹⁾	Min	Typ ⁽²⁾	Max	Unit
V _{PV}	Pull-up supply voltage (open drain)	(Addr/Therm)	-0.3		3.6	V
		$\overline{\text{EVENT}}$, SDA, SCL	-0.3		5.5	V
V _{POR}	Power On Reset threshold (POR) - TS	V _{DD} falling edge		1.75		V
t _{TIMEOUT}	SMBus timeout ⁽⁵⁾		25		35	ms
t _{SP}	Spike suppression Pulse width of spikes that must be suppressed by the input filter	Input filter on SCL and SDA			50	ns

- Valid for ambient operating temperature: T_A = -40 to +125 °C; V_{DD} = 2.25 V to 3.6 V (except where noted).
- Typical numbers are for T_A = +25 °C; V_{DD} = 3.0 V
- Not tested, guaranteed by design.
- Accuracy measurements made at resolutions > 10 bits.
- SMBus timeout min and max are valid for T_A = -30 to +125 °C.

Table 29. AC characteristics

Symbol	Description	Min	Typ	Max	Unit
f _{SCL}	SMBus/I ² C clock frequency	10		400	kHz
t _{HIGH}	Clock high period	600			ns
t _{LOW}	Clock low period	1.3			μs
t _R	Clock/data rise time			300	ns
t _F	Clock/data fall time			300	ns
t _{SU:DAT}	Data setup time	100			ns
t _{HD:DI}	Data in hold time	0			ns
t _{HD:DAT}	Data out hold time	300			ns
t _{SU:STA}	Start condition setup time	600			ns
t _{HD:STA}	Hold time after (repeated) start condition. After this period, the first clock cycle is generated.	600			ns
t _{SU:STO}	Stop condition setup time	600			ns
t _{BUF}	Bus free time between stop (P) and start (S) conditions	1.3			μs

9 Package information

In order to meet environmental requirements, ST offers these devices in different grades of ECOPACK packages, depending on their level of environmental compliance. ECOPACK specifications, grade definitions and product status are available at: www.st.com. ECOPACK is an ST trademark.

9.1 UDFN-6L package information

Figure 9. UDFN-6L (2 mm x 2 mm x 0.5 mm) package outline

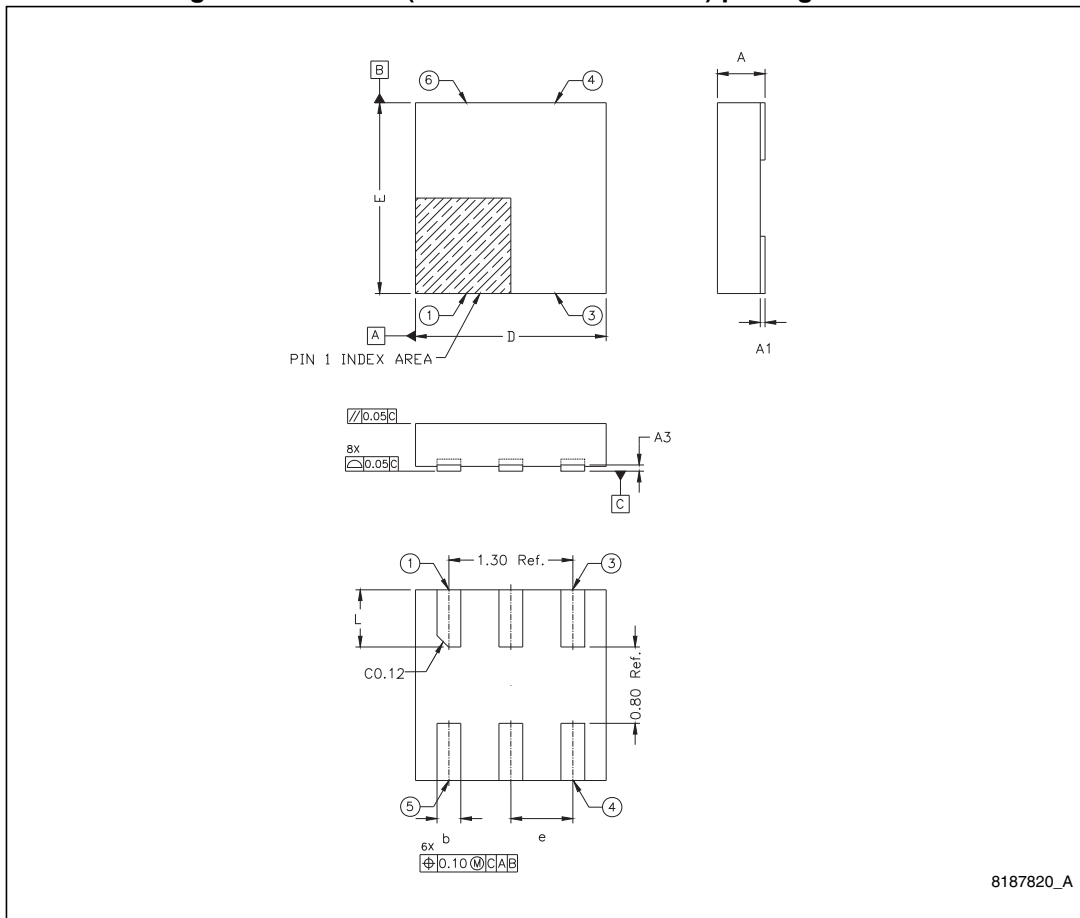
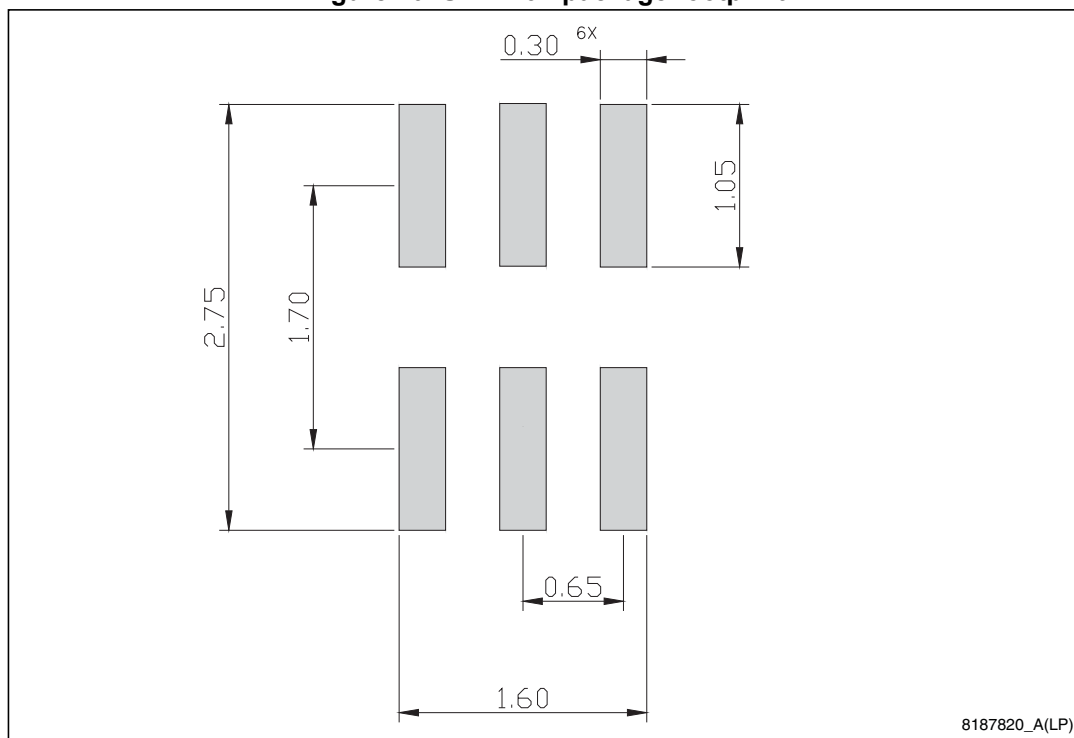

Table 30. UDFN-6L (2 mm x 2 mm x 0.5 mm) package mechanical data

Sym	mm			inches		
	Min	Typ	Max	Min	Typ	Max
A	0.45	0.50	0.55	0.018	0.020	0.022
A1	0.00		0.05	0.000		0.002
A3		0.065			0.003	
b	0.20	0.25	0.30	0.008	0.010	0.012
D	1.95	2.00	2.05	0.077	0.079	0.081
E	1.95	2.00	2.05	0.077	0.079	0.081
e		0.65			0.026	
L	0.50	0.60	0.70	0.020	0.024	0.028

Figure 10. UDFN-6L package footprint



8187820_A(LP)

9.2 Packing information

Figure 11. Carrier tape for UDFN-6L package

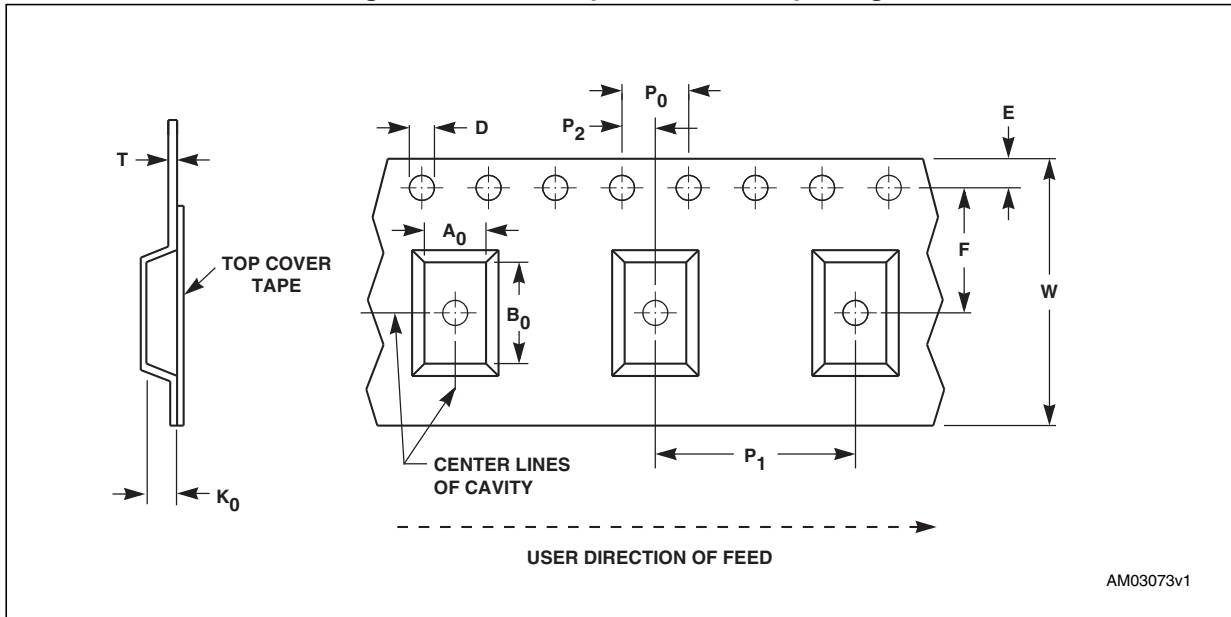

Table 31. Carrier tape dimensions for UDFN-6L package

Package	W	D	E	P_0	P_2	F	A_0	B_0	K_0	P_1	T	Unit
UDFN-6L	8.00 ± 0.30	1.50 $+0.10/-0.00$	1.75 ± 0.10	4.00 ± 0.10	2.00 ± 0.05	3.50 ± 0.05	2.20 ± 0.10	2.20 ± 0.10	0.75 ± 0.10	4.00 ± 0.10	0.25 ± 0.05	mm

Figure 12. Reel schematic

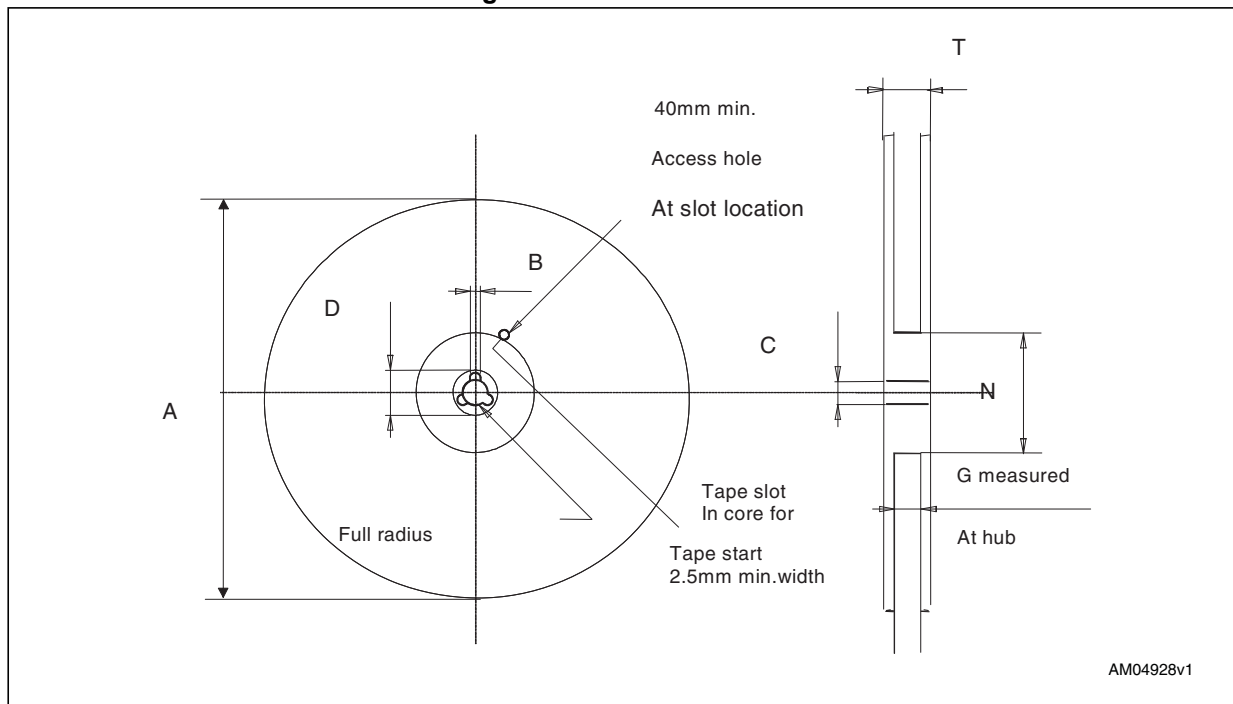

Table 32. Reel dimensions for 8 mm carrier tape - UDFN-6L package

A (max)	B (min)	C	D (min)	N (min)	G	T (max)
180 mm (7 inch)	1.5 mm	13 mm ± 0.2 mm	20.2 mm	60 mm	8.4 mm + 2/-0 mm	14.4 mm

Note: The dimensions given in [Table 32](#) incorporate tolerances that cover all variations on critical parameters.

10 Part numbering

Table 33. Ordering information scheme

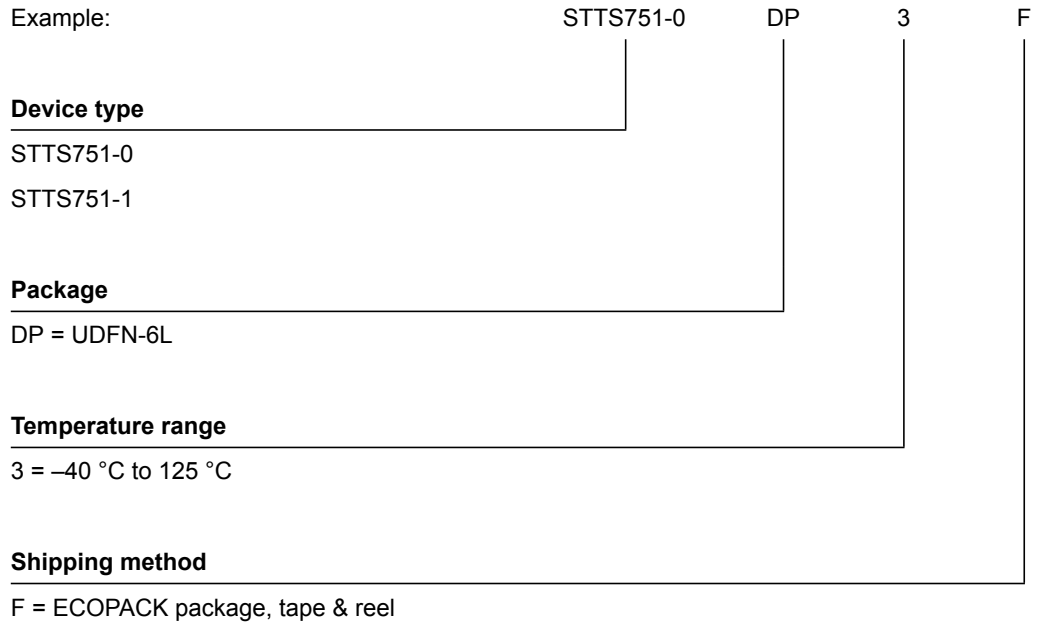

For other options, or for more information on any aspect of this device, please contact the ST sales office nearest you.

11 Revision history

Table 34. Document revision history

Date	Revision	Changes
06-Nov-2009	1	Initial release.
21-Jan-2010	2	Updated Features; removed <u>Therm2</u> throughout document (from Section 1, 2, 3.8, 4.6, 4.10, 5, Figure 1, 2, 3, 4, 6, Table 2, 3, 15, 28); updated Figure 3, Section 3.4, Section 4.6, Section 4.8, Section 4.10, Table 10, 11, 12, 13, 14, 15, 17, 18, 19, 20, 21, 22, 23, 24, 25; added package footprints (Figure 11 and 12); minor textual changes.
12-May-2010	3	Updated Section 3.7, Section 4.11, Section 5; Figure 6, 7, 11, 12; Table 3, 9, 25, 28, 31; added tape and reel information (Figure 13, 14 and Table 32, 33); minor textual changes in title and document.
01-Jul-2010	4	Document status promoted to full datasheet; updated cover page; added footnote to Table 28; minor textual changes.
20-Jul-2010	5	Removed footnote from Table 28.
10-Sep-2018	6	Updated Accuracy in <i>Features</i> and <i>Table 28: DC and AC characteristics</i>
17-May-2019	7	Removed SOT23-6L package option

IMPORTANT NOTICE – PLEASE READ CAREFULLY

STMicroelectronics NV and its subsidiaries (“ST”) reserve the right to make changes, corrections, enhancements, modifications, and improvements to ST products and/or to this document at any time without notice. Purchasers should obtain the latest relevant information on ST products before placing orders. ST products are sold pursuant to ST’s terms and conditions of sale in place at the time of order acknowledgement.

Purchasers are solely responsible for the choice, selection, and use of ST products and ST assumes no liability for application assistance or the design of Purchasers’ products.

No license, express or implied, to any intellectual property right is granted by ST herein.

Resale of ST products with provisions different from the information set forth herein shall void any warranty granted by ST for such product.

ST and the ST logo are trademarks of ST. For additional information about ST trademarks, please refer to www.st.com/trademarks. All other product or service names are the property of their respective owners.

Information in this document supersedes and replaces information previously supplied in any prior versions of this document.

© 2019 STMicroelectronics – All rights reserved

Mouser Electronics

Authorized Distributor

Click to View Pricing, Inventory, Delivery & Lifecycle Information:

[STMicroelectronics:](#)

[STTS751-0WB3F](#) [STTS751-1WB3F](#) [STTS751-0DP3F](#) [STTS751-1DP3F](#)